

DENON

Hi-Fi Component

SERVICE MANUAL MODEL DN-2000F



V05545

DOUBLE CD PLAYER



TABLE OF CONTENTS

OPERATING INSTRUCTIONS	2-12
DISASSEMBLY	13-15
LOADER FRAME ASSEMBLING	16
NOTE FOR HANDLING OF LASER PICK-UP	17
SERVO ADJUSTMENT	18
IC TERMINAL FUNCTION LIST	22-30
PRINTED WIRING BOARD PARTS LIST	33, 34
PRINTED WIRING BOARD PATTERNS	35, 36
PARTS LIST OF EXPLODED VIEW	38
EXPLODED VIEW OF CHASSIS AND CABINET	39
PARTS LIST OF FG-50 MECHA UNIT	40
EXPLODED VIEW OF FG-50 MECHA UNIT	40
PARTS LIST OF RC-35 REMOTE CONTROL UNIT	40
EXPLODED VIEW OF RC-35 REMOTE CONTROL UNIT	41
WIRING DIAGRAM	42
SCHEMATIC DIAGRAM	43, 44
SEMICONDUCTORS	45-47

NIPPON COLUMBIA CO., LTD.

IMPORTANT TO SAFETY

WARNING:

TO PREVENT FIRE OR SHOCK HAZARD, DO NOT EXPOSE THIS APPLIANCE TO RAIN OR MOISTURE.

CAUTION:

1. **Handle the power supply cord carefully**
Do not damage or deform the power supply cord. If it is damaged or deformed, it may cause electric shock or malfunction when used. When removing from wall outlet, be sure to remove by holding the plug attachment and not by pulling the cord.
2. **Do not open the top cover**
In order to prevent electric shock, do not open the top cover. If problems occur, contact your DENON dealer.
3. **Do not place anything inside**
Do not place metal objects or spill liquid inside the CD player. Electric shock or malfunction may result.

Please, record and retain the Model name and serial number of your set shown on the rating label.

Model No. DN-2000F Serial No. _____

CAUTION
RISK OF ELECTRIC SHOCK
DO NOT OPEN

CAUTION: TO REDUCE THE RISK OF ELECTRIC SHOCK, DO NOT REMOVE COVER (OR BACK). NO USER-SERVICEABLE PARTS INSIDE. REFER SERVICING TO QUALIFIED SERVICE PERSONNEL.

The lightning flash with arrowhead symbol, within an equilateral triangle, is intended to alert the user to the presence of uninsulated "dangerous voltage" within the product's enclosure that may be of sufficient magnitude to constitute a risk of electric shock to persons.

The exclamation point within an equilateral triangle is intended to alert the user to the presence of important operating and maintenance (servicing) instructions in the literature accompanying the appliance.

IMPORTANT (BRITISH MODEL ONLY)

The wires in this mains lead are coloured in accordance with the following code:

Blue: Neutral Brown: Live

The colours of the wires in the mains lead of this apparatus may not correspond with the coloured markings identifying the terminals in your plug proceed as follows.

The wire which is coloured blue must be connected to the terminal which is marked with the letter N or coloured black.

The wire which is coloured brown must be connected to the terminal which is marked with the letter L or coloured red.

NOTE:

This CD player uses the semiconductor laser. To allow you to enjoy music at a stable operation, it is recommended to use this in a room of 5°C (41°F) – 35°C (95°F).

LABELS (for U.S.A. model only)

WARNING SHOCK HAZARD
DANGEROUS VOLTAGE INSIDE DO NOT OPEN
AVIS RISQUE DE CHOC ELECTRIQUE
NE PAS OUVRIR.

CAUTION
RISK OF ELECTRIC SHOCK
DO NOT OPEN

WARNING TO REDUCE THE RISK OF FIRE OR ELECTRIC SHOCK, DO NOT EXPOSE THIS EQUIPMENT TO RAIN OR MOISTURE

CERTIFICATION
THIS PRODUCT COMPLIES WITH DHS RULES 21 CFR SUBCHAPTER J APPLICABLE AT DATE OF MANUFACTURE.
DENON AMERICA INC. 222 NEW ROAD PARLISIPPANY, NEW JERSEY 07054 U.S.A.

MODEL NO	DN-2000F	DENON
~120V	26W	50Hz
SER. NO.		

NIPPON COLOMBIA CO., LTD. MADE IN JAPAN

CAUTION:

USE OF CONTROLS OR ADJUSTMENTS OR REFORMANCE OF PROCEDURES OTHER THAN THOSE SPECIFIED HEREIN MAY RESULT IN HAZARDOUS RADIATION EXPOSURE.

THE COMPACT DISC PLAYER SHOULD NOT BE ADJUSTED OR REPAIRED BY ANYONE EXCEPT PROPERLY QUALIFIED SERVICE PERSONNEL.

NOTE:

This unit may cause interference to radio and television reception if you do not operate it in strict accordance with this OPERATING INSTRUCTIONS.

This unit complies with Class B computing device rules in accordance with the specifications in Sub-part J or Part 15 of the FCC Rules, which are designed to provide reasonable protection against such interference in a residential installation. If the unit does cause interference to any radio or television reception, try to reduce it by one or more of the following means:

- a) Turn the other unit to improve reception
- b) Move this unit
- c) Move this unit away from others
- d) Plug this unit respectively into a different AC outlet

* This is note in accordance with Section 15.838 of the FCC Rules.

SAFETY INSTRUCTIONS



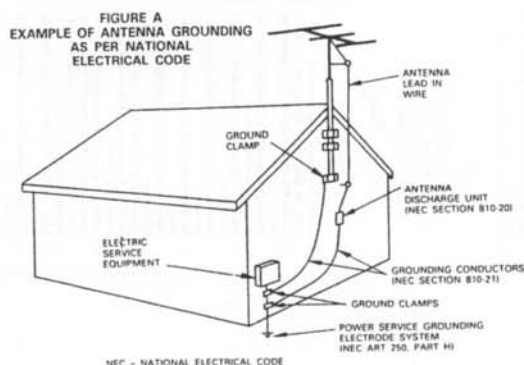





1. Read Instructions – All the safety and operating instructions should be read before the appliance is operated.
2. Retain Instructions – The safety and operating instructions should be retained for future reference.
3. Heed Warnings – All warnings on the appliance and in the operating instructions should be adhered to.
4. Follow Instructions – All operating and use instructions should be followed.
5. Water and Moisture – The appliance should not be used near water – for example, near a bathtub, washbowl, kitchen sink, laundry tub, in a wet basement, or near a swimming pool, and the like.
6. Carts and Stands – The appliance should be used only with a cart or stand that is recommended by the manufacturer.
- 6A. An appliance and cart combination should be moved with care. Quick stops, excessive force, and uneven surfaces may cause the appliance and cart combination to overturn.
7. Wall or Ceiling Mounting – The appliance should be mounted to a wall or ceiling only as recommended by the manufacturer.
8. Ventilation – The appliance should be situated so that its location or position does not interfere with its proper ventilation. For example, the appliance should not be situated on a bed, sofa, rug, or similar surface that may block the ventilation openings; or, placed in a built-in installation, such as a bookcase or cabinet that may impede the flow of air through the ventilation openings.
9. Heat – The appliance should be situated away from heat sources such as radiators, heat registers, stoves, or other appliances (including amplifiers) that produce heat.
10. Power Sources – The appliance should be connected to a power supply only of the type described in the operating instructions or as marked on the appliance.
11. Grounding or Polarization – The precautions that should be taken so that the grounding or polarization means of an appliance is not defeated.
12. Power-Cord Protection – Power-supply cords should be routed so that they are not likely to be walked on or pinched by items placed upon or against them, paying particular attention to cords at plugs, convenience receptacles, and the point where they exit from the appliance.
13. Cleaning – The appliance should be cleaned only as recommended by the manufacturer.
14. Power Lines – An outdoor antenna should be located away from power lines.
15. Outdoor Antenna Grounding – If an outside antenna is connected to the receiver, be sure the antenna system is grounded so as to provide some protection against voltage surges and built up static charges. Section 810 of the National Electrical Code, ANSI/NFPA No. 70-1984, provides information with respect to proper grounding of the mast and supporting structure, grounding of the lead-in wire to an antenna discharge unit, size of grounding conductors, location of antenna-discharge unit, connection to grounding electrodes, and requirements for the grounding electrode. See Figure A.
16. Nonuse Periods – The power cord of the appliance should be unplugged from the outlet when left unused for a long period of time.
17. Object and Liquid Entry – Care should be taken so that objects do not fall and liquids are not spilled into the enclosure through openings.
18. Damage Requiring Service – The appliance should be serviced by qualified service personnel when:
 - A. The power-supply cord or the plug has been damaged; or
 - B. Objects have fallen, or liquid has been spilled into the appliance; or
 - C. The appliance has been exposed to rain; or
 - D. The appliance does not appear to operate normally or exhibits a marked change in performance; or
 - E. The appliance has been dropped, or the enclosure damaged.
19. Servicing – The user should not attempt to service the appliance beyond that described in the operating instructions. All other servicing should be referred to qualified service personnel.



— CONTENTS —

1	GENERAL	6
	Describes the features and operating precautions for the DN-2000F. Be sure to read this section before use.	
	Main Features	6
2	PREPARATION	6
	(1) Check the Contents	6
	(2) Install the Units	6
	(3) Connections	7
3	DESCRIPTION OF THE FUNCTIONS	8
	Describes in detail the names of the various parts and functions of the main unit and the remote control unit.	
	(1) Names, Dimensions, and Functions of the Parts of the Main Unit	8
	(2) Names, Dimensions, and Functions of the Parts of the Remote Control Unit	9
4	BASIC OPERATION	10
	Describes the operations, necessary when using the unit for mixing.	
	(1) Loading and Ejecting the Disc	10
	(2) Selecting Tracks and play mode	11
	(3) Starting Play	11
	(4) Stopping Play	12
	(5) Description of the PLAY/PAUSE, and CUE Operations	13
	(6) Matching the Beat Per Minute	14
	(7) Beat Matching Using Pitch Bend	15
	(8) Moving the Play Start Position	15
	(9) Checking the Play Start Position	17
5	EXAMPLE OF MIXING WITH THE DN-2000F	18
6	BEFORE SWITCHING OFF THE POWER	19
7	COMPACT DISCS	19
8	SPECIFICATIONS	20

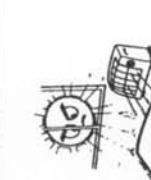
NOTE ON USE/HINWEISE ZUM GEBRAUCH/OBSERVATIONS RELATIVES A L'UTILISATION
NOTE SULL'USO/NOTAS SOBRE EL USO/ALVORENS TE GEBRUIKEN/OBSERVERA
OBSERVAÇÕES QUANTO AO USO

 <ul style="list-style-type: none"> Do not let foreign objects in the set. Keine fremden Gegenstände in das Gerät kommen lassen. Ne pas laisser des objets étrangers dans l'appareil. E' importante che nessun oggetto è inserito all'interno dell'unità. No debe dejar objetos extraños dentro del equipo. Kein fremde Gegenstände in das Gerät einlegen. Se till att främmande föremål inte tränger in i apparaten. Não deixe objetos estranhos no aparelho. 	 <ul style="list-style-type: none"> Do not let insecticides, benzene, and thinner come in contact with the set. Lassen Sie das Gerät nicht mit Insektiziden, Benzin oder Verdünnungsmitteln in Berührung kommen. Ne pas mettre en contact des insecticides, du benzène et un diluant avec l'appareil. Assicuratevvi che l'unità non venga in contatto con insetticidi, benzolo o solventi. Kein Insektizid, Benzin oder Verdünnungsmittel in Berührung mit dem Gerät. Last geen insecticideverdelgende middelen, benzine of verdundingen met dit apparaat in contact komen. Kein Insektizid, Benzin oder Verdünnungsmittel in Berührung mit dem Gerät. Não permita que inseticidas, benzina e solventes entrem em contacto com o aparelho. 	 <ul style="list-style-type: none"> Never disassemble or modify the set in any way. Versuchen Sie niemals das Gerät auseinander zu nehmen oder auf jegliche Art zu modifizieren. Ne jamais démonter ou modifier l'appareil d'une manière ou d'une autre. Non smontare mai, né modificare l'unità in nessun modo. Kein auseinandernehmen oder modifizieren des Gerätes. Kein auseinandernehmen oder modifizieren des Gerätes. Noot dit apparaat demonteren of op andere wijze wijzigen. Te ikke islar apparaten, eller fôrsøk å endre den på annen måte. Nunca desmonte ou modifique o aparelho de alguma forma.
 <ul style="list-style-type: none"> Keep the set free from moisture, water, and steam. Halten Sie das Gerät von Feuchtigkeit, Wasser und Staub fern. Protéger l'appareil contre l'humidité, l'eau et la poussière. Evitare l'umidità, l'acqua e la polvere. Mantenga el equipo libre de humedad, agua y polvo. Laat geen vochtigheid, water of stof in het apparaat vallen. Uthatt inte apparaten för fukt, vatten och damm. Mantenha o aparelho livre de qualquer umidade, água ou poeira. 	 <ul style="list-style-type: none"> Unplug the power cord when not using the set for long periods of time. Wenn das Gerät eine längere Zeit nicht verwendet werden soll, trennen Sie das Netzkabel vom Netzstecker. Quando non si utilizza l'appareil per lunghi periodi di tempo, scollegare il filo di alimentazione quando il set non viene utilizzato. Desconecte el cordón de energía cuando no utilice el equipo por mucho tiempo. Wanneer het apparaat gedurende een lange periode niet wordt gebruikt, koppel u afkabelen om apparaten in te nemen uit het stopcontact. Koppla ur nåkabeln om apparaten inte kommer att användas i lång tid. Não desligue o fio de alimentação quando o aparelho não tiver que ser usado por um longo período. 	 <ul style="list-style-type: none"> *For sets with ventilation holes: Do not obstruct the ventilation holes. Verhindern Sie die Belüftungslöcher nicht verdeckt werden. Ne pas obstruer les trous d'aération. Non coprire i fori di ventilazione. No obstruya los orificios de ventilación. Wanneer het apparaat ingezet wordt, mogen niet worden blokkeerd. Tepp ikke å blokkere ventilasjonsåpningarna. Não obstrua os orificios de ventilação.
 <ul style="list-style-type: none"> Avoid high temperatures. Allow for sufficient heat dissipation when installed on a rack. Vermeiden Sie hohe Temperaturen. Beachten Sie, daß eine ausreichende Luftzirkulation gewährleistet wird, wenn das Gerät auf ein Regal gestellt wird. Eviter des températures élevées. Garantir suficiente dissipação de calor durante a instalação. Evitate di esporre l'unità a temperature alte. Assicuratevvi che ci sia un'adeguata dissipazione del calore quando installate l'unità in un mobile per componenti audio. Evite altas temperaturas. Permita que haja suficiente dissipação de calor durante a instalação. Vermeid hoge temperaturen. Zorg voor een degelijk hittekoeler indien het apparaat op een rek wordt geplaatst. Se till att det finns tillräckligt till god värmeavledning vid montering i ett rack. Evite temperaturas altas. Conceda suficiente dissipação de calor quando o equipamento for instalado numa prateleira. 	 <ul style="list-style-type: none"> Handle the power cord carefully. Hold the plug when unplugging the cord. Uthatt den utgående kablens utseende när du lossnar kablarna från uttaget. Halten Sie das Kabel am Stecker, wenn Sie den Stecker herausziehen. Manipuler le cordon d'alimentation avec précaution. Tepp ikke å ta på kablene når du demonterer dem. Manneggiare il filo di alimentazione con cura. Per la spina quando scollegate il cavo dalla presa. Maneje el cordón de energía con cuidado. Sossegue el enchufe cuando desconecte el cordón de energía. Handle the power cord carefully. Houd het snoer bij de stecker vast wanneer deze moet worden aan- of losgemaakt. Hetens nikkabeln varsamt. Haltdet kablenn nær den kopplas i/in ei- eller uttaket. Manuseie com cuidado o fio condutor de energia. Segura a tomada ao desconectar o fio. 	

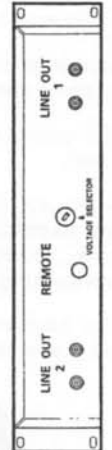

Line Voltage Selection (for multiple voltage model only)

- The desired voltage may be set with the VOLTAGE SELECTOR knob on the rear panel, using a screwdriver.
- Do not twist the VOLTAGE SELECTOR knob with excessive force as this may cause damage.
- if the VOLTAGE SELECTOR knob does not turn smoothly, please contact a qualified serviceman.

CAUTION:
Whenever the power switch is in the OFF state, the apparatus is still connected on AC line voltage. Please be sure to unplug the cord when you leave home for, say, a vacation.
Be sure turn on POWER switch after a Remote cable of RC-35 is connected to the Player unit, otherwise, the apparatus may not work correctly.

1 GENERAL

Main Features
 The DN-2000F is a double CD player which provides excellent performance as well as a variety of functions ideal for DJ mixing. The unit can be mounted in a standard 19-inch rack.

- Button switches between remaining time and elapsed time
- Digital display indicates playing time of the CD player
- Track selection buttons
- Search buttons for cueing inside a track
- Back cue function is convenient for rehearsals
- Instant start is required for DJ mixing
- Pitch bend function permits beat timing to be matched
- Sliding Fader for varying the pitch up to $\pm 8\%$
- 19-inch rack mountable
- Lightweight remote control connection cable

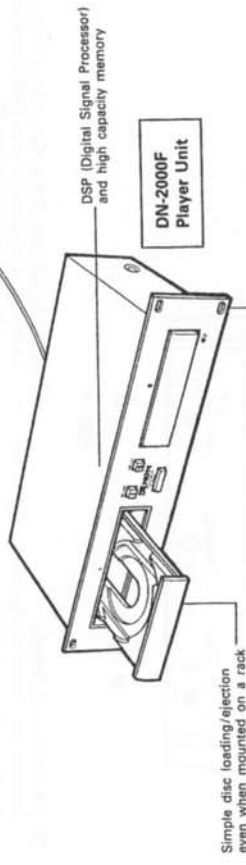
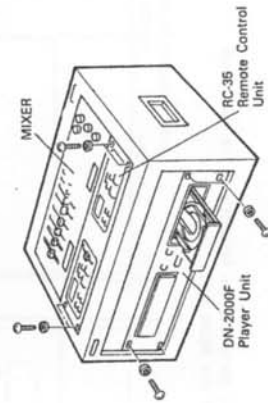

Figure 1

2 PREPARATION

- (1) Check the Contents
- Check that the carton contains the following items in addition to the main unit.
- ① Operating instructions 1
 - ② Connection cords for signal output (RCA) 2
 - ③ Remote control unit (RC-35) 1
 - ④ Remote control connection cable 1
 - ⑤ Connecting brackets with screws 1 pair

- (2) Install the Units
- ① Mount the units onto the DJ console with 19" EIA rack rails. (Example-1)



- ② Mount the units onto the rack with 19" EIA rack rails. (Example-2)
- ③ To operate the units on the desk top, use the connecting brackets provided.

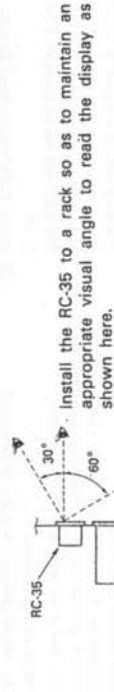
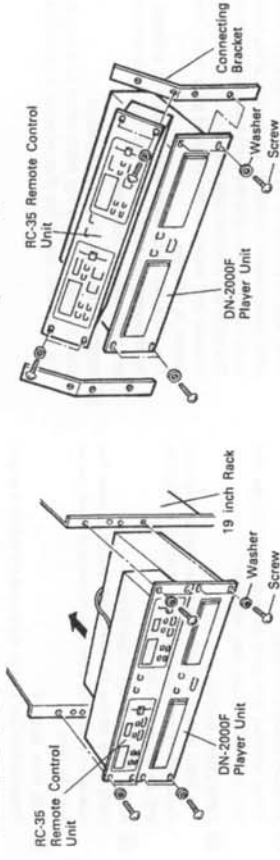

Install the RC-35 to a rack so as to maintain an appropriate visual angle to read the display as shown here.

- (3) Connections
- Typical connections with a mixer is illustrated below. Please use it for reference.

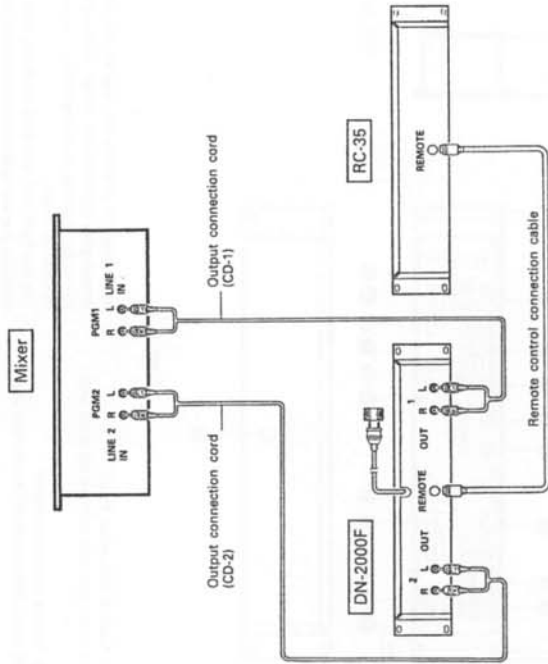

Figure 2

- Connect the connection cords to the line inputs of your mixer.
- The connection cords and the remote control connection cable are supplied with the main unit.
- Be sure to use the remote control connection cable which has been supplied. Use of another cable type might cause damage.

3 DESCRIPTION OF THE FUNCTIONS

Below is a description of the names of the various parts and the functions of the main unit.

(1) Names, Dimensions, and Functions of the Parts of the Main Unit

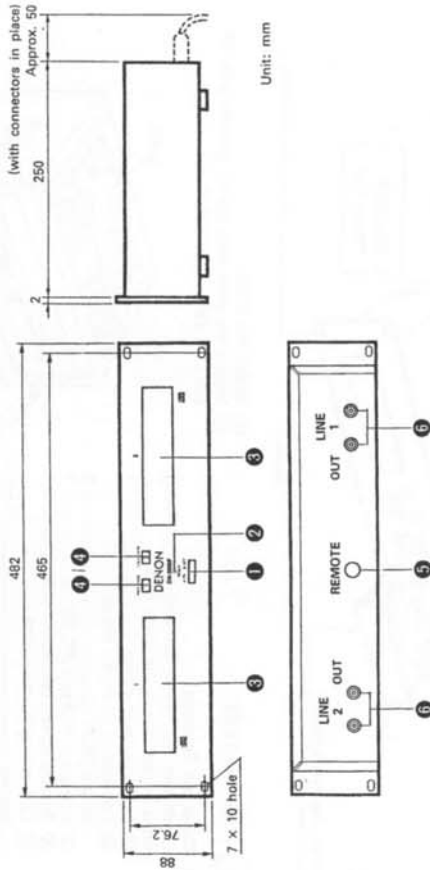

Figure 3

- 1 POWER (Power Switch)**
Switches the power of the main unit and the remote control on and off. Power indicator **2** is lit when the power is on.
- 2 POWER (Power Indicator)**
Lights up red when power switch **1** is on.
- 3 Disc Holder**
The disc is placed on this holder. Pressing the disc holder open/close buttons **4** will open and close each of the holders. When loading the CD, place it securely in the disc holder.
- 4 OPEN/CLOSE (Disc Holder Open/Close Button)**
Press to load or eject the disc. Each press will open or close the disc holder **3**. The remote control is also equipped with similar buttons.
- 5 REMOTE (Remote Control Connector)**
This connector accepts the cable which connects to the remote control unit RC-35. Insert the plug securely as far as it will advance.
- 6 LINE OUT (Output Jacks)**
The audio from each CD player is output from these jacks. Connect to the line input of the mixer. Red is for the right channel and white, the left channel.

(2) Names, Dimensions, and Functions of the Parts of the Remote Control Unit

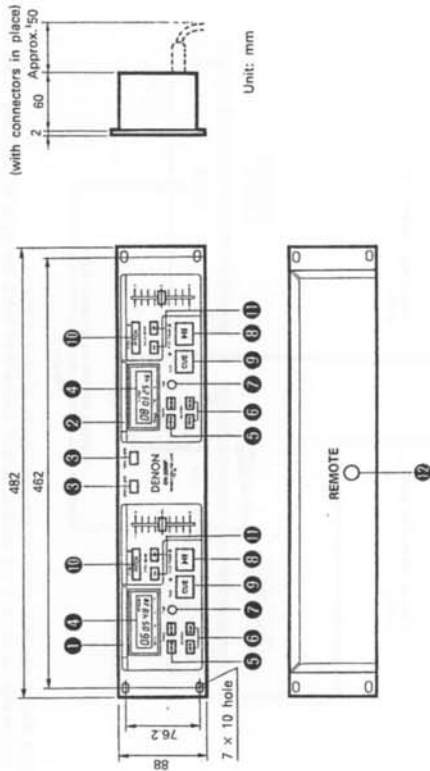

Figure 4

- 1 CD-1 Remote Control Operation Panel**
This operation panel remotely controls the main unit CD-1.
- 2 CD-2 Remote Control Operation Panel**
This operation panel remotely controls the main unit CD-2.
- 3 OPEN/CLOSE (Disc Holder Open/Close Button)**
Press to load or eject the disc. Each press will open or close the disc holder **3**.
- 4 Time Display**
This display shows the track number, time (minutes, seconds and frames), and elapsed or remaining time. Each frame represents 1/75 of a second.
- 5 TRACK (Track Button)**
This button selects the track to be played.
- 6 SEARCH (Search Buttons)**
These buttons are used to accurately change the positions where disc play will start.
- 7 TIME (Time Button)**
The TIME button switches the time display between elapsed time and remaining time. ELAPSE or REMAIN will be shown on the display.
- 8 PLAY/PAUSE (Play/Pause Button)**
Each press of the PLAY/PAUSE button causes the operation to change from play to pause or from pause back to play.
- 9 CUE (Cue Button)**
Pressing the CUE button during play provides a return to the position at which play was started. Alternately pressing the PLAY/PAUSE button and the CUE button allows the CD to be played from the same position any number of times. The red CUE LED will blink from the time the CUE button is pressed until the CD has reset to the position at which play was started. Steady lighting of this LED indicates the ready condition.
- 10 PITCH (Pitch Button)**
This button changes the play speed. The pitch can be changed up to $\pm 8\%$ by pressing the PITCH button so the green PITCH LED is lit, then moving the sliding fader. The pitch will not be changed if the green PITCH LED is off.
- 11 PITCH BEND (Pitch Bend Button)**
When each of the two CD players are playing a CD, the pitch bend function allows the positioning of the bass beats to be matched after the pitch has been matched. The pitch will automatically rise while the + button is pressed and return to the original pitch when the button is released. The pitch will drop while the - button is pressed. By changing the pitch in this way, the positioning of the beats can be matched.
- 12 REMOTE (Remote Control Connector)**
This connector accepts the cable which connects to the main unit. Insert the plug securely as possible.

4 BASIC OPERATION

(1) Loading and Ejecting the Disc

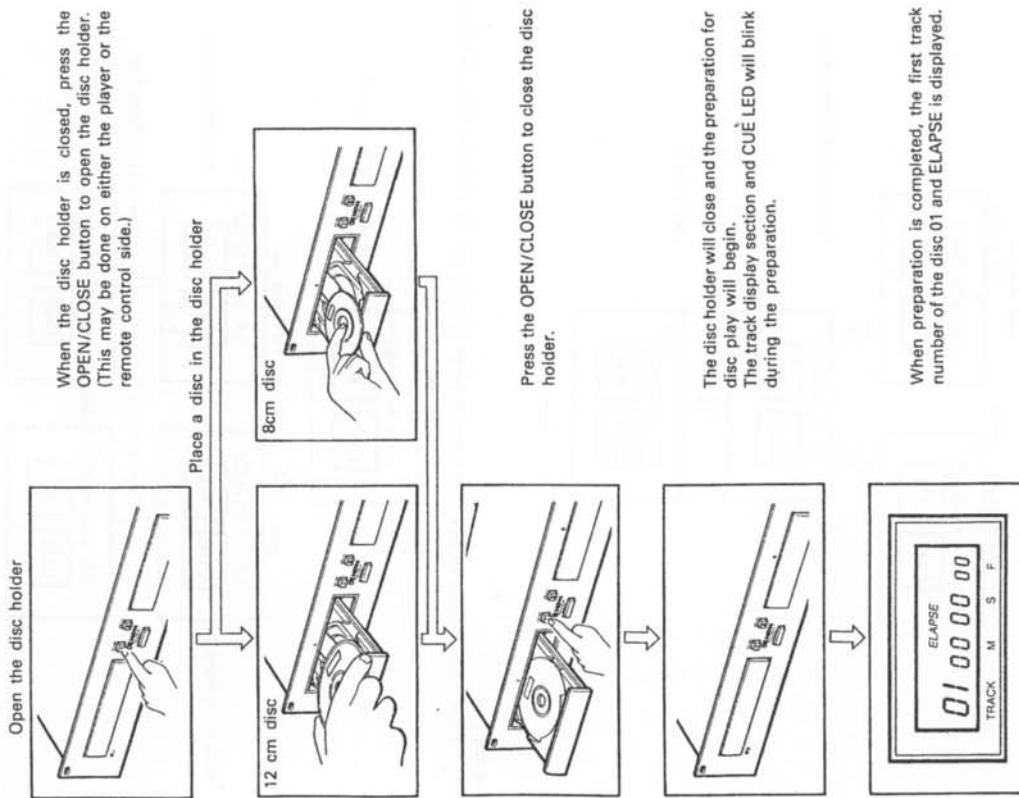

Figure 5

(2) Selecting Tracks and play mode

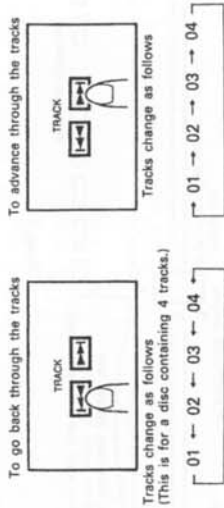

Figure 6

Each press of the TRACK button changes 1 track. Continuing to hold the TRACK button down provides an automatic change at a higher speed which is convenient for discs that contain many tracks.

During the track selection operation, the track indication of the display will blink and the M S F indication will be off.

When a new track is selected during play, after the selection operation is completed, play will immediately start from the beginning of the newly selected track.

The track number can be selected before loading a disc on the player unit. You can select a track to play on the controller, then load a disc. The player will cue up to your selected track automatically.

SINGLE/CONTINUE play mode selection

• Press the TIME and \pm buttons of PITCH BEND simultaneously to set the player for SINGLE track playback mode, "S" is displayed on TRACK section.
During single playback mode, the player stops after a specified track is played back.

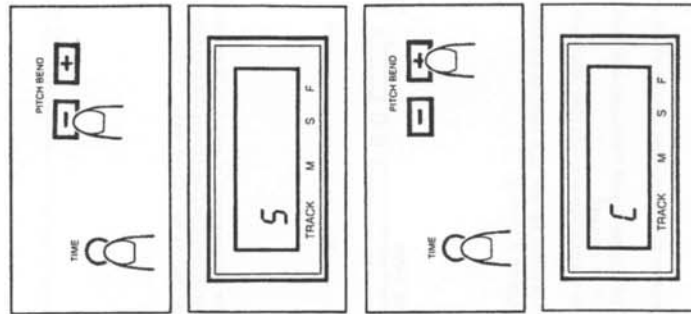

• Press the TIME and \pm button of PITCH BEND simultaneously to set the player for continuous playback mode, "C" is displayed on TRACK section.
During continuous playback mode, the player continue playback until completion of playback of the last track on the disc.

• When the power switch to ON, the player automatically set to CONTINUE playback mode.

- (3) **Starting Play**
Pressing the PLAY/PAUSE button during the pause condition or after the completion of back cue will start disc play.

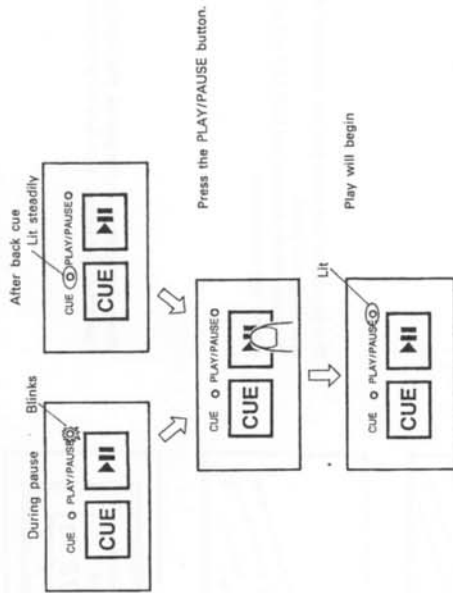

Figure 7

- (4) **Stopping Play**
There are two ways of stopping play. One uses the pause function and the other the back cue function.

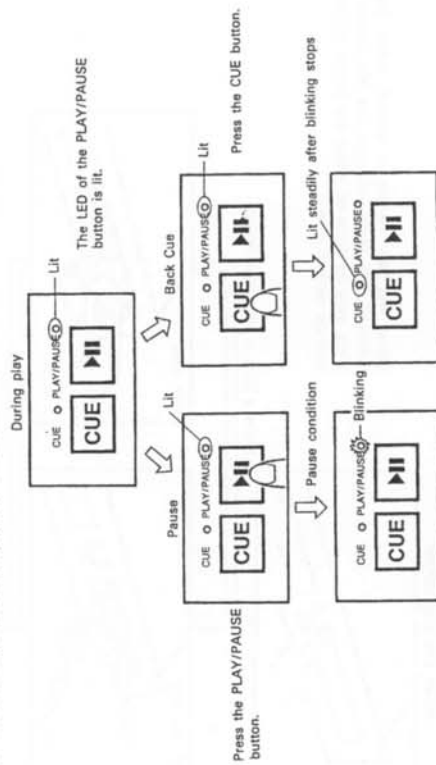

Figure 8
The LED of the PLAY/PAUSE button blinks. (The CD pauses at the position where the PLAY/PAUSE button was pressed during play.)
Back cue operation. First the LED of the CUE button blinks, then it lights steadily after the operation is completed. (The CD returns to the position where the disc was started from.)

- (5) **Description of the PLAY/PAUSE, and CUE Operations**

- Each press of the PLAY/PAUSE button causes the operation to change from play to pause or from pause back to play.
 - The play operation of this CD player is performed via DSP (Digital Signal Processor) and memory, so the audio starts instantly after the PLAY/PAUSE button is pressed.
 - Pressing the CUE button during disc play resets the CD to the position at which play was started. (This is called the back cue function.)
- The steps through which disc play is performed when the PLAY/PAUSE and CUE buttons are pressed are described with the aid of the following illustrations in Figures 9 through 11.

PLAY and PAUSE

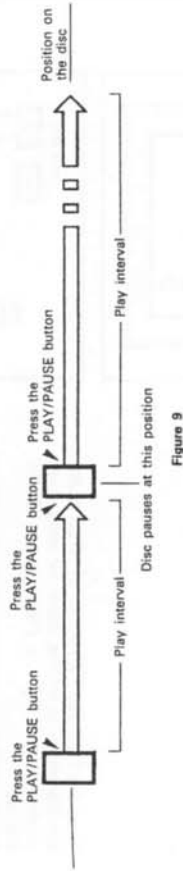

Figure 9

Pressing the PLAY/PAUSE button starts the disc play, the advancement of which is illustrated by the arrows of Figure 9. Pressing the PLAY/PAUSE button again during disc play causes the play operation to pause, and pressing this button once more causes the disc to be played again.

PLAY and CUE



Figure 10

Pressing the PLAY/PAUSE button starts the disc. Pressing the CUE button will reset the disc to the position where play was started. By alternately pressing the PLAY/PAUSE button and the CUE button, the disc may be played from the same position any number of times. This function is called back cue.

PLAY, PAUSE, and CUE

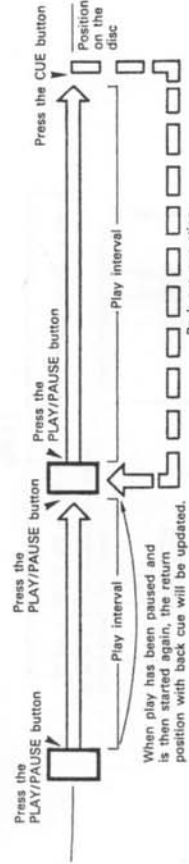

Figure 11

- (7) **Beat Matching Using Pitch Bend**
 A description of the procedure for matching the beat of CD-1 and CD-2 using the PITCH BEND button is given below.
 This description is for the case of matching the beat of CD-2 to the beat of the music being played on CD-1.

After Matching the BPM's According to Section (6)

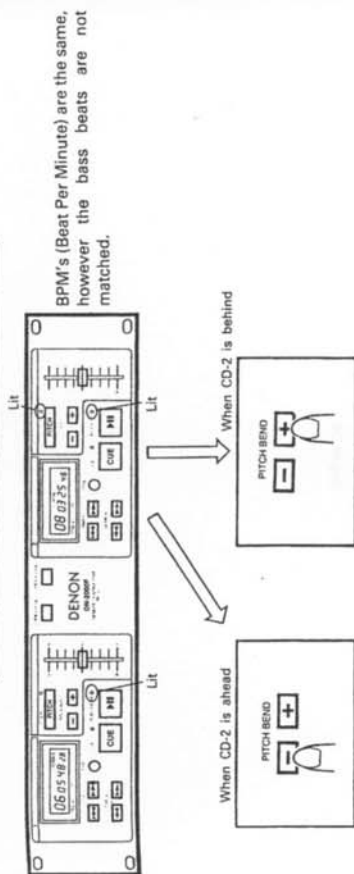
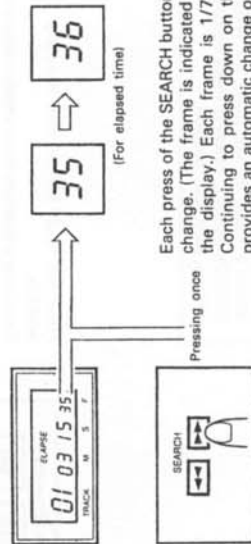

Figure 13

The pitch changes automatically while the **+** or **-** button is being pressed. Releasing the button results in a return to the original pitch. (So the BPM's are once again the same.)

- (8) **Moving the Play Start Position**
 When a track is selected and the PLAY/PAUSE button is pressed, the play operation will start from the beginning of that track. However, when you want play to start from a different position, use the following procedure to find that position.



Each press of the SEARCH button causes .1 frame to change. (The frame is indicated at the F portion of the display.) Each frame is 1/75th of a second. Continuing to press down on the SEARCH button provides an automatic change of frames, the speed of which increases while the button is pressed.

Figure 14

- (6) **Matching the Beats Per Minute**
 Match the pitch by monitoring the music of both CD-1 and CD-2 by ear. When the tempo of the music of the selected CD player is slow compared to the tempo of the other player, move the slider to the + side and match the tempo. When fast, move to the - side. The following description is for the case of matching the pitch of CD-2 to the pitch of the music being played on CD-1.

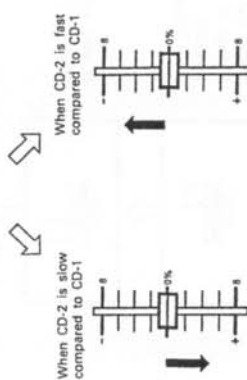
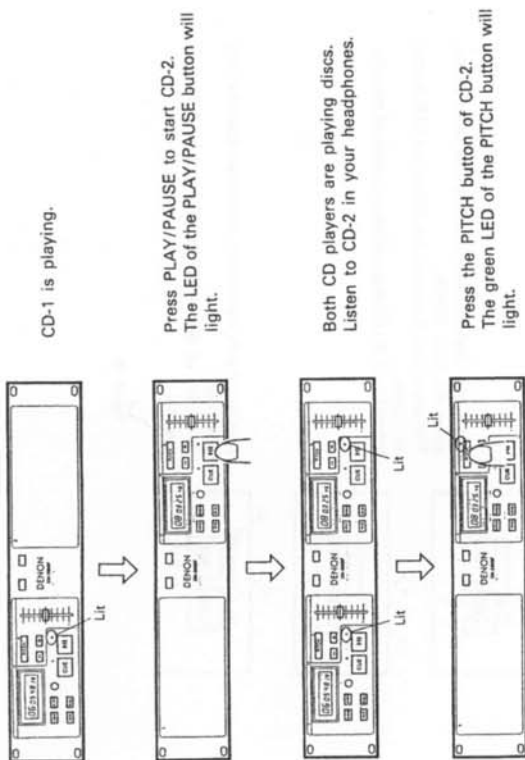

Figure 12

To Start Playback from the Middle of a track.

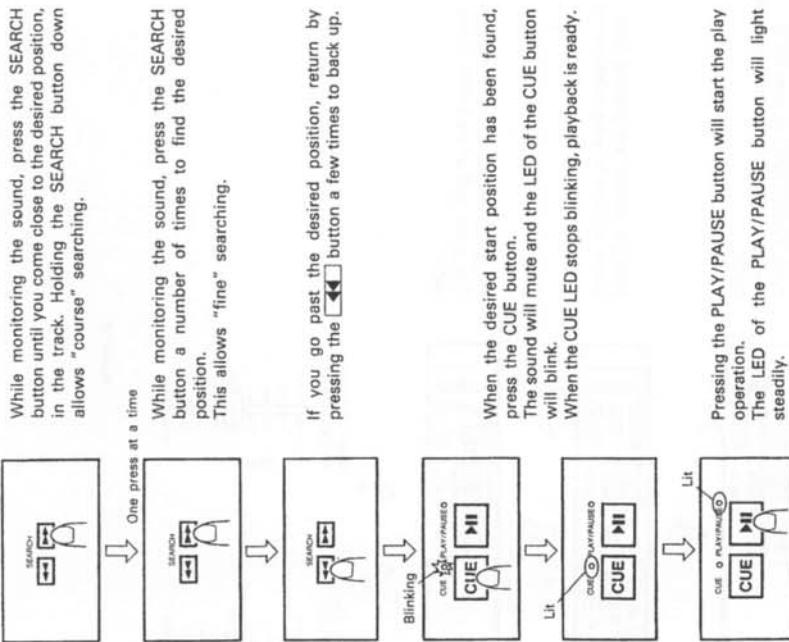

Figure 15

(9) Checking the Play Start Position
After selecting the track or after changing the play start position with the SEARCH button, use the following procedure to repeatedly check the position at which play will start.

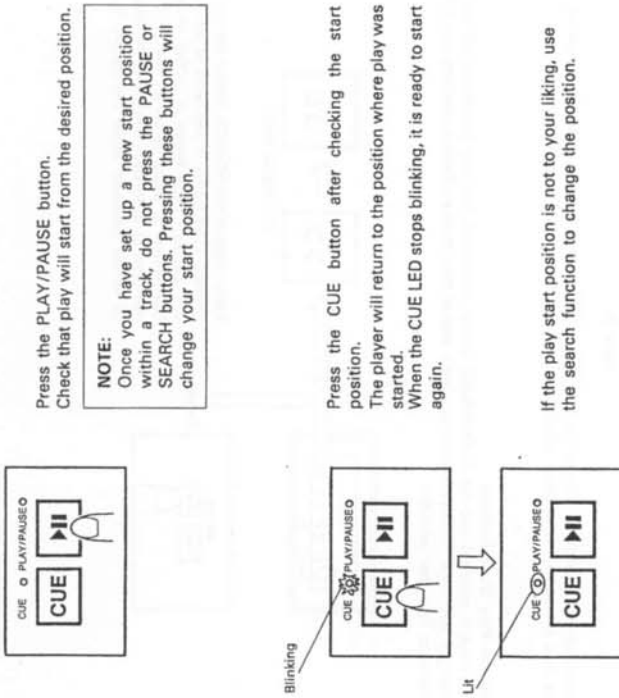

Figure 16

5 EXAMPLE OF MIXING WITH THE DN-2000F

A description of an actual example of mixing using the system illustrated in Figure 2 is given below. After playing back a track on CD-1, and after matching the pitch of CD-2, use cross fader on your mixer to fade from CD-1 to CD-2.

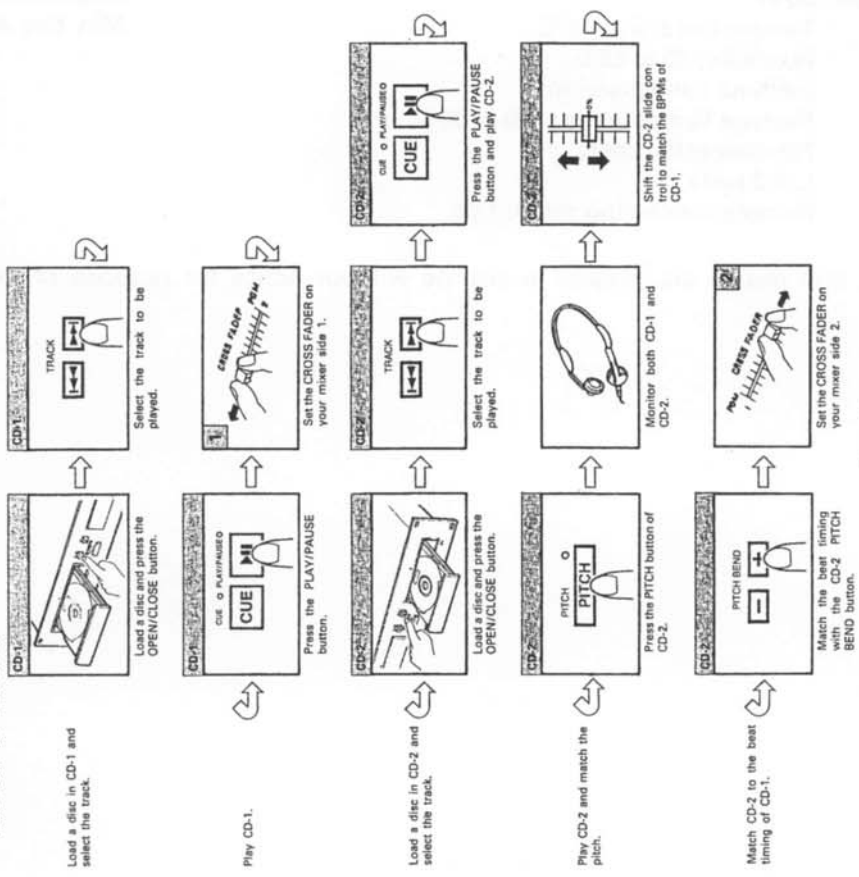

Figure 17

6 BEFORE SWITCHING OFF THE POWER

When you have finished using the CD player, before switching off the power be sure that the disc holder has been closed with the OPEN/CLOSE button.

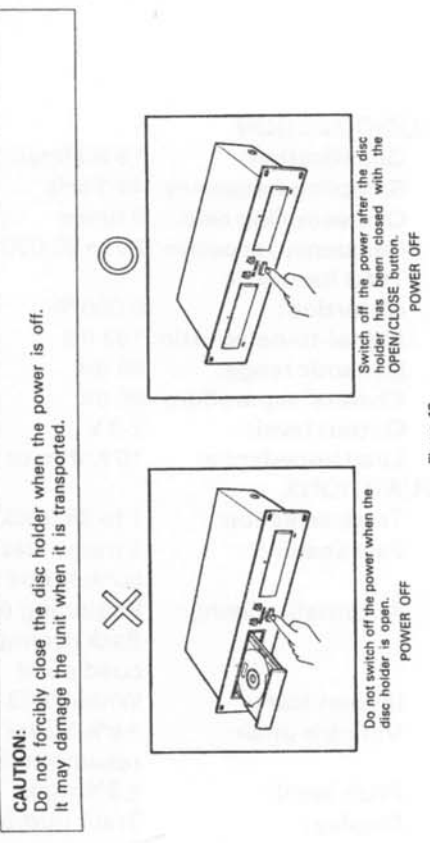

Figure 18

7 COMPACT DISCS

- 1. Precautions on handling compact discs**
 - Do not allow fingerprints, oil or dust to get on the surface of the disc. If the disc is dirty, wipe it off with a soft dry cloth.
 - We recommend using DENON's AMC-20/21 CD CLEANER.
 - Do not use benzene, thinner, water, record spray, electrostatic-proof chemicals, or silicone-treated cloths to clean discs.
 - Always handle discs carefully to prevent damaging the surface; in particular when removing a disc from its case or returning it.
 - Do not bend the disc.
 - Do not apply heat.
 - Do not enlarge the hole in the center of the disc.
 - Do not write on the label (printed side) with a hard-tipped implement such as a pencil or ball point pen.
 - Condensation will form if a disc is brought into a warm area from a colder one, such as outdoors in winter. Do not attempt to dry the disc with a hair dryer, etc.
- 2. Precaution on storage**
 - After playing a disc, always unload it from the player.
 - Always store the disc in the jewel case to protect from dirt or damage.
 - Do not place discs in the following areas:
 - Areas exposed to direct sunlight for a considerable time.
 - Areas subject to accumulation of dust or high humidity.
 - Areas affected by heat from indoor heaters, etc.

8 SPECIFICATIONS

GENERAL

Type:	Twin mechanism Compact Disc player with wired remote control.
Disc type:	Standard Compact Discs (12 cm and 8 cm)
Dimensions:	Player unit; 482 (W) × 88 (H) × 252 (D) mm Remote control unit; 482 (W) × 88 (H) × 62 (D) mm
Installation:	19-inch rack mountable Player unit; 3U Remote control unit; 3U
Weight:	Player unit; 5.5 kg Remote control unit; 1.5 kg
Power supply:	120 V AC ±10%, 60 Hz (for U.S.A. & Canada models) 230 V AC ±10%, 50/60 Hz (for European model) 240 V AC ±10%, 50/60 Hz (for U.K. model) 120/220/240 V AC ±10%, 50/60 Hz (for multi voltage version)
Power consumption:	26 W
Environment:	Temperature; 5 to 35°C Humidity; 25 to 85% (without condensation) Storage Temperature; -20 to 60°C
Standard accessories:	Pin-connected cord; L/R 2 pairs Remote connecting cable; 1 pc.

AUDIO SECTION

Quantization:	18-bit linear/channel
Sampling frequency:	44.1 kHz
Oversampling rate:	8 times
Frequency response:	20 to 20,000 Hz
Total harmonic distortion:	0.006 %
Signal-to-noise ratio:	103 dB
Dynamic range:	98 dB
Channel separation:	96 dB
Output level:	2.0 V
Load impedance:	10 Kohm or more

FUNCTIONS

Track selection:	1 to 99 tracks
Fast search:	1 frame step and continuous search
Automatic cueing:	Beginning of music Back cueing to cued point
Instant start:	Within 0.03 sec.
Variable pitch:	±8% Slider with resume switch ±8% max.
Pitch bend:	±8% max.
Display:	Track number, Remaining time or Elapsed time in Min. Sec. and Frame

* Specifications and design are subject to change without notice for purpose of improvement.

DISASSEMBLY

● TOP COVER

1. Remove 4 screws (105) on both sides, and 1 screw (101) on rear side.
2. Pull up TOP COVER.

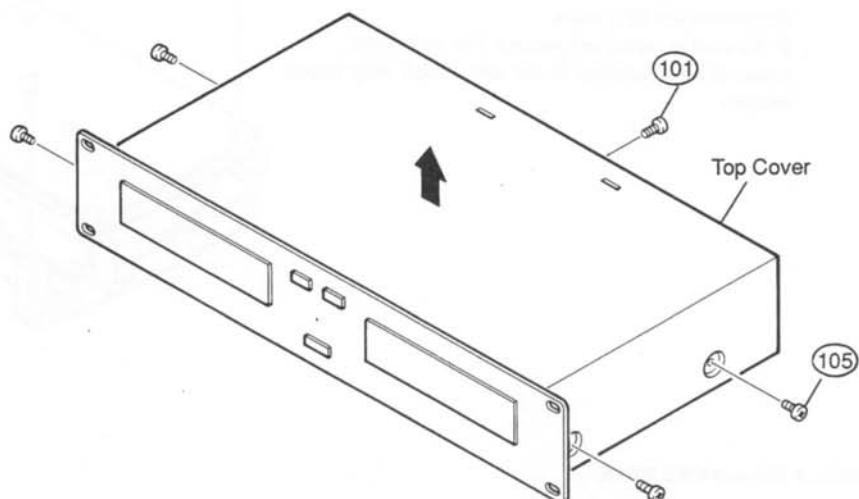

● FRONT PANEL

1. LOADER FRAME comes out when SLIDE RACK (A) of mechanism unit is pushed.
2. Pull up LOADER PANEL while pulling it towards front.
3. Remove 2 upper screws (101) and 3 lower screws (101).
4. Detach FRONT PANEL.

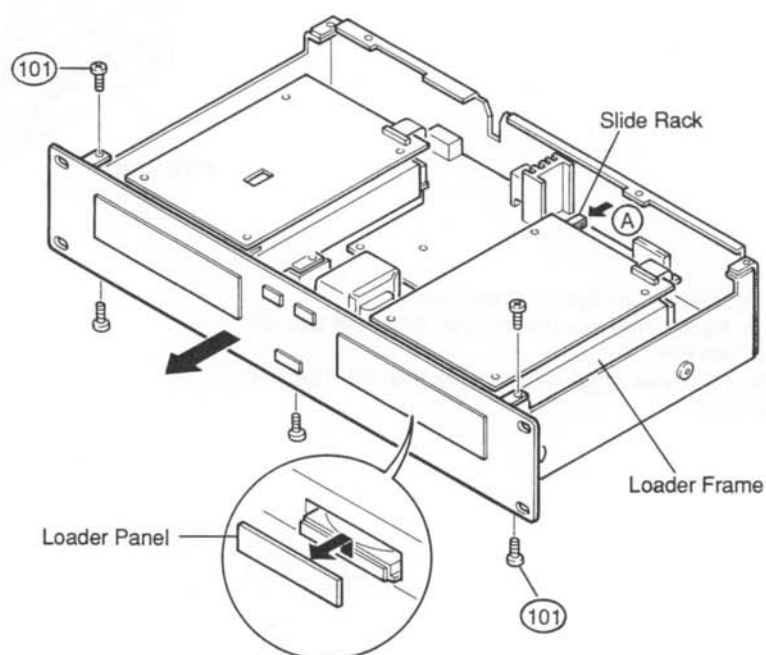

● MECHANISM UNIT

1. Disconnect FFC cable.
2. Remove 4 screws (102).

Note : ● Do not pull out aslant to prevent FFC cable damage.
 ● Do not fail to pull AC cord from wall outlet before disconnect the FFC cable .
 IF AC cord is remained plugged into wall outlet, power is kept supplied in the unit, which may cause danger.

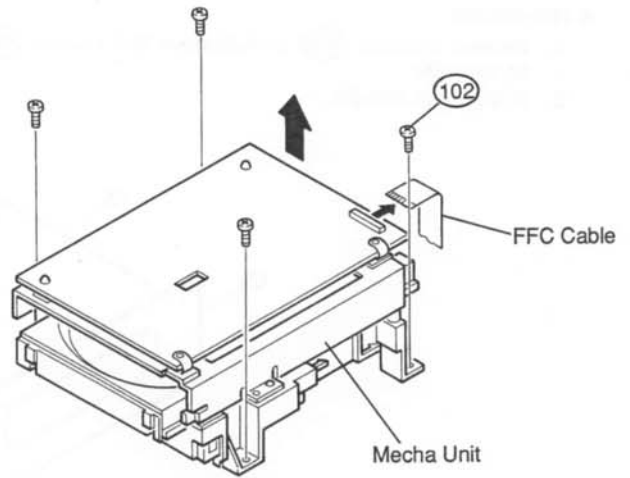

● MECHA. PWB and PWB BASE

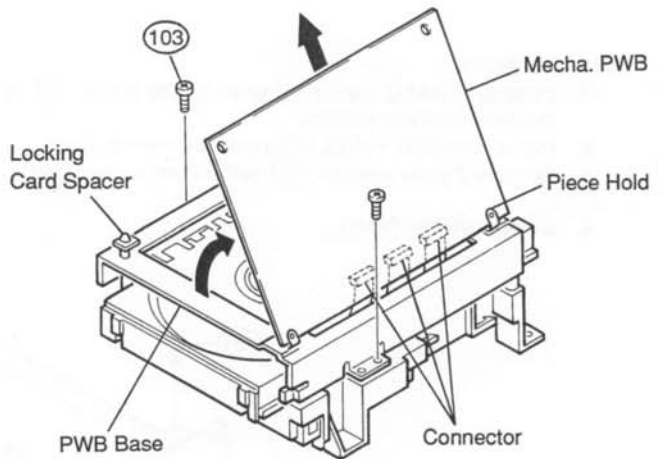

1. Unlock Locking Card Spacer at two places.
2. Rotate Mecha.PWB upwards (approx. 45°), and take off from Piece Hold.
3. Remove 2 screws (103) on both sides, then PWB Base is detachable.

● CLAMPER

Pull clamber and undo 4 hooks.

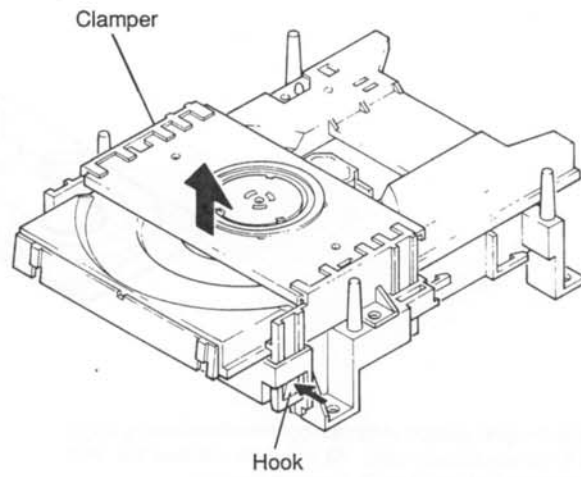
**● COVER (REMOTE CONTROL UNIT)**

1. Remove 5 screws (1 (103) and 4 (101)).

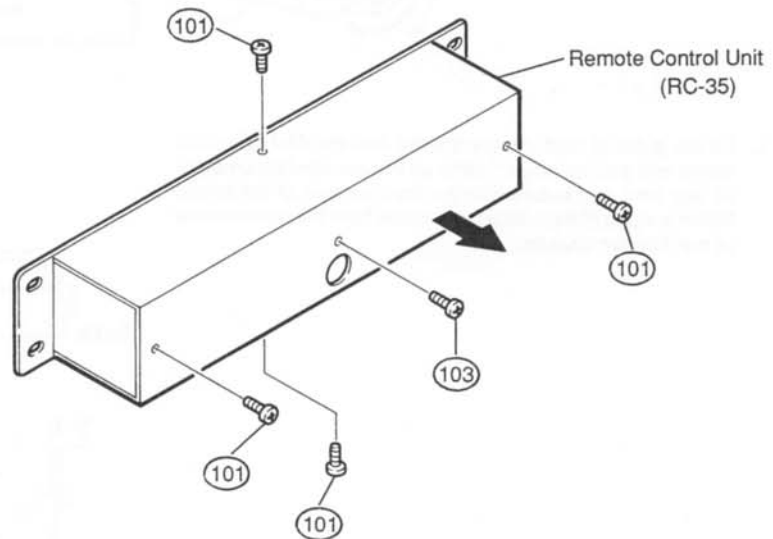

LOADER FRAME ASSEMBLING

1. Slide the slide rack located inner side of the loader frame, and set the lock lever as shown in the below figure.

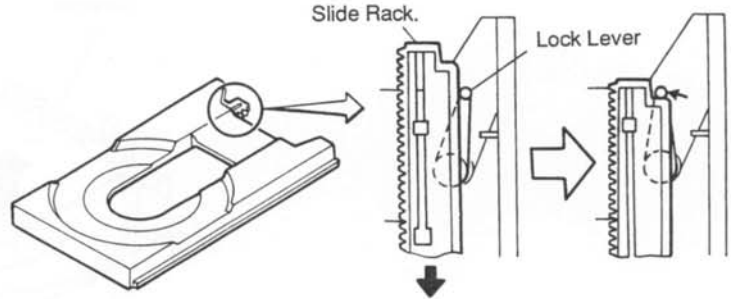

2. Rotate the gear portion of lift cam counterclockwise by finger until it comes stopper part. At this time, confirm the drive mechanism that is placed in lowered position.

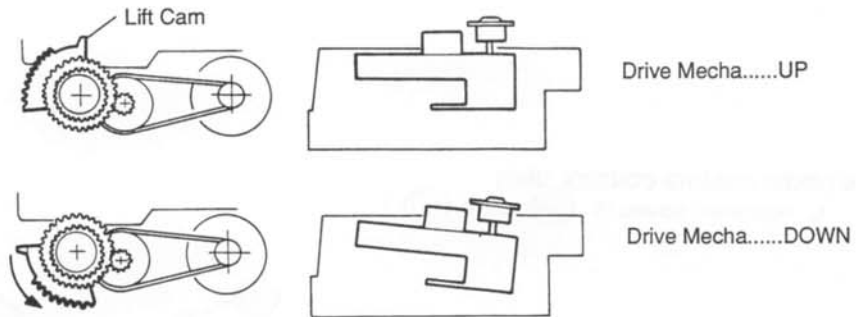

3. Fit the guide of mechanism chassis and the ditch of loader frame and put the loader frame on the mechanism chassis. At this time, make sure that the front surface of the loader frame is set at 20mm extruded position from the front surface of mechanism chassis.

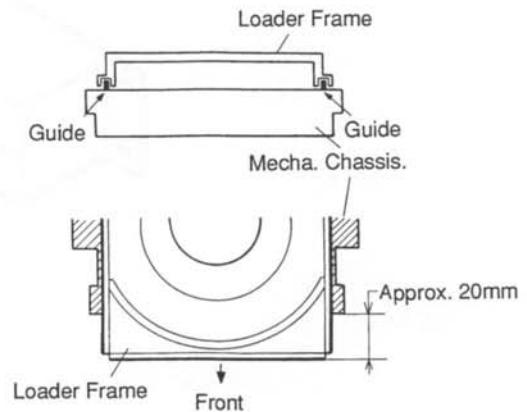

4. Insert the clamber frame to the mechanism chassis until it locks.

**NOTE FOR HANDLING OF LASER PICK-UP
DESCRIPTION OF THE COMPONENTS**

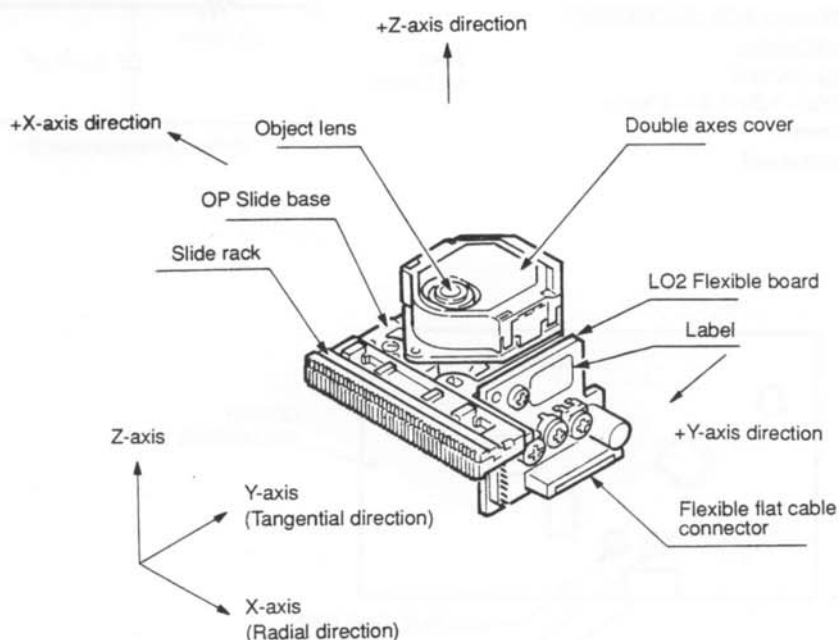

Label

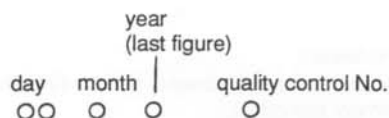
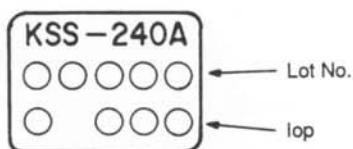

but Oct. Nov. and Dec. are expressed by alphabetical letters of X, Y and Z.

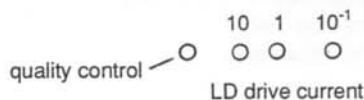

The expressed unit is by mA, with omission of the decimal point as for example, 56.5mA will be expressed as 565, but the head of English letter means the control in the manufacturing plant.

PIN CONNECTOR

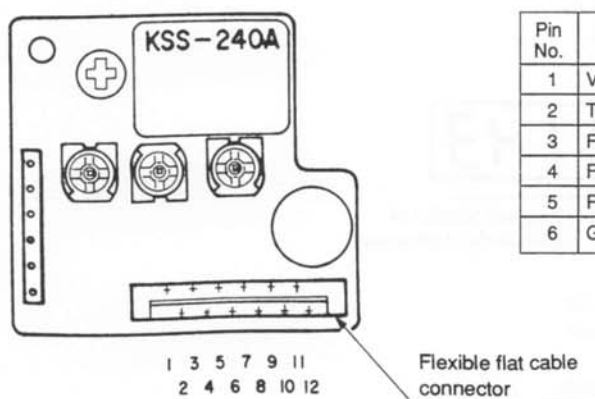

Pin No.	Description	Input/Output	Pin No.	Description	Input/Output
1	VC (+2.5v)	OUT	7	Vcc (+5V)	IN
2	TE (TRK ER signal)	OUT	8	LDC (LD Control)	IN
3	FE (FCS ER signal)	OUT	9	FCS + (Double axes)	IN
4	FZC (FZC signal)	OUT	10	TRK + (Double axes)	IN
5	RF (RF signal)	OUT	11	TRK - (Double axes)	IN
6	GND	IN	12	FCS - (Double axes)	IN

SERVO ADJUSTMENT

NECESSARY EQUIPMENTS FOR ADJUSTMENT

1. Dual trace oscilloscope
2. Reference disc CA1094
3. Oscillator (10Hz – 10kHz, 0 – 3 Vp-p)
4. Frequency Counter
5. Filter for measurement

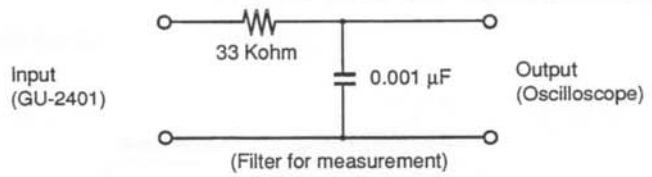

LOCATION

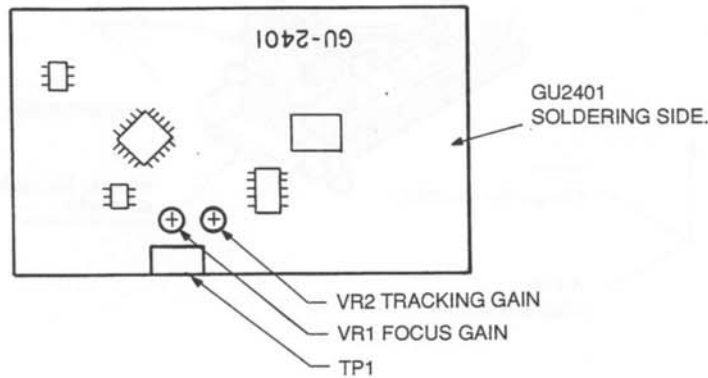

Adjustment Procedure





Be sure to perform servo adjustments and confirmations by this order of adjustment procedure.

- 1 Actuating the Service Program.
- 2 Confirmation of Tracking Offset.
- 3 Adjustment of Focus Gain.
- 4 Adjustment of Tracking Gain.
- 5 Confirmation of HF Waveform.

1. Actuating the Servo Program

- ① Turn the power off.
- ② While simultaneously pushing the center blue buttons (1,2) of remote control (RC-35), turn the power on.
- ③ As the tray opens, set the adjustment disc (CA-1094).
- ④ Displayed indication on the remote control (RC-35) is version number of microcomputer program 4 figures on the left are program version of remote control, and 4 figures on the right are program version of main body mechanism.





- ⑤ Push the TRACK  button of the mechanism intended to adjust for one time. After confirm that  is displayed, push the PLAY button. Then, the Tray will close.
- ⑥ Push the TRACK  button ( is indicated), then push the PLAY button.

2. Confirmation of Tracking Offset

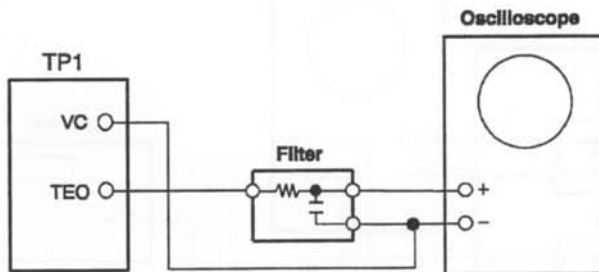
① Connections



- ② Push the TRACK  button ( is indicated), then push the PLAY button.
- ③ Observe TEO on the scope.

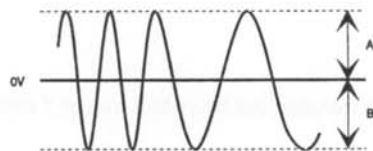



Measure the voltage of A,B and in case $\frac{|A-B|}{A+B}$ exceeds 15%, please replace pick-up as it is defected.

3. Adjustment of Focus Gain

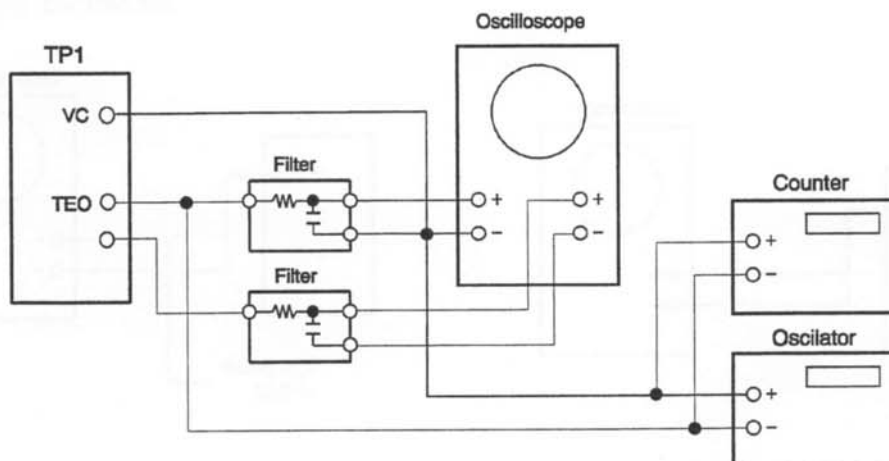
① Connections



- ② Push the TRACK  Button ( is indicated), then push the PLAY button.
- ③ Set the oscillator 1.1kHz, 0.6 Vp-p mode.
- ④ Make the oscilloscope in X-Y mode.
- ⑤ Adjust the VR1 () so as to symmetrize Lissajous figure to X axis or Y axis.

4. Adjustment of Tracking Gain

① Connections

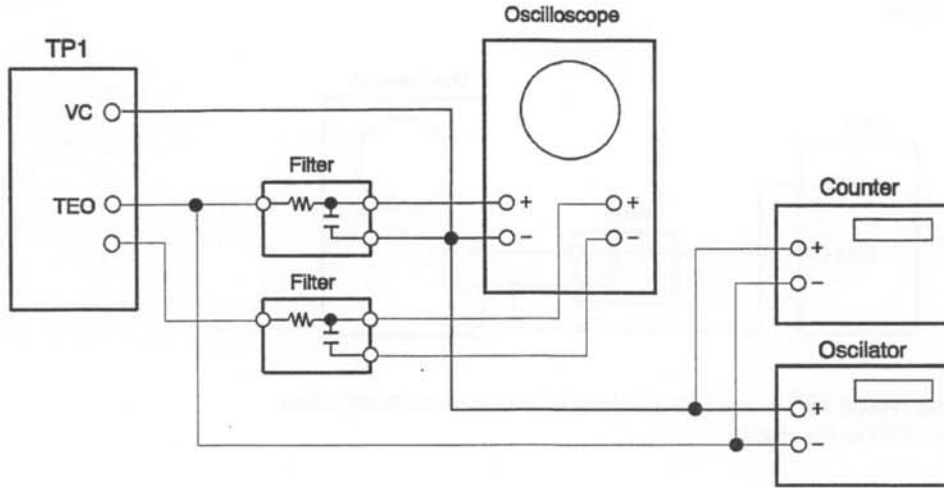

- ② Confirm that $B4$ is indicated.
- ③ Set the oscillator 1.9kHz, 0.6Vp-p mode.
- ④ Make the oscilloscope in X-Y mode.
- ⑤ Adjust the VR2 (TRACK) so as to symmetrize Lissajous figure to X axis or Y axis.

5. Confirmation of HF Waveform

① Connections

For PWB Item No. 222 2401 207

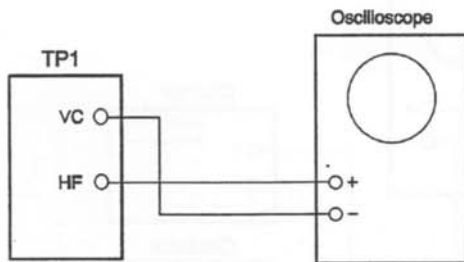

For PWB Item Nos. 222 2401 003
222 2401 100

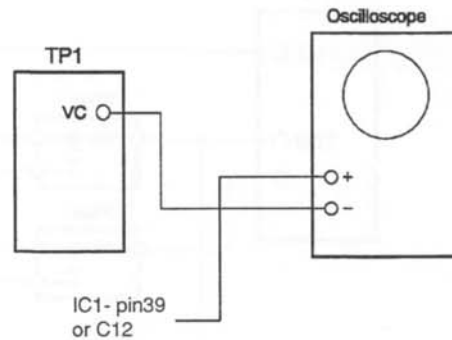

- ② Observe HF waveform on the scope.
- ③ The standard amplitude of HF waveform is 1.1V. If it is less than 0.8V, please replace pick-up as it is defected.

6. Adjustment of Super Linear Converter

Adjustment of Super Linear Converter is only performed at a time the DA Converter is replaced.

Adjustment Procedure

- ① Connections
Connect the LINE OUT to a distortion meter through the low-pass filter.
- ② Playback a disc obtains 1kHz, 0dB sine wave tone.
- ③ Adjust the VR300, VR301 and obtain minimum THD.

VR300 R-channel
VR301 L-channel

THD standard is less than 0.006%

About the Service Program







The service program is a program specially for servo adjustments and for confirmations.

Actuating the Service Program.

- ① Turn the power off.
- ② While simultaneously pushing the center blue buttons (1,2) of remote control (RC-35), turn the power on.
- ③ Program version of microcomputer indicated on the remote control signifies start actuating of service program.

Contents of Service Program

After actuating the service program, select an aiming process number with the TRACK ( ) buttons, TIME button, PITCH BEND button, and PITCH button, and push the PLAY button to execute processing, The process number is then displayed on the TRACK indication portion.

	Process No. (TRACK Indication)	Function	Contents Explanation
TRACK BUTTONS  	01	OPEN/CLOSE	Performs OPEN/CLOSE each time the PLAY button is pushed.
	02	Slide	Moves pick-up to the center of disc.
	03	FOCUS SERVO ON	Turns the FOCUS Servo ON.
	04	Confirmation of TRACKING OFFSET	Rotates the disc. Checks divergence of Tracking Offset.
	05	Adjustment of Gain	Adjusts FOCUS, TRACKING Gains. Normally the same as PLAY MODE.
	06	Cleaning of Pick-up Lens	Pick-up. moves when SEARCH ( ) button is pressed. Move the pick-up under the hole of mechanism PWB, and clean the lens.
TIME	0A	CHUCKING Test	Repeats OPEN/CLOSE of tray, servo ON, and TOC read.
PITCH BEND 	0B	Heat Run (No Skip Check)	Repeats OPEN/CLOSE of tray, repeats playing the first and the last programs of music on the disc. When an error occurs, displays error code and stops.
PITCH BEND 	0C	Heat Run (With Skip Check)	Repeats OPEN/CLOSE of tray, repeats playing the first and the last program of music on the disc. Stops when skip (track jump) occurs.

IC TERMINAL FUNCTION LIST

TABLE OF MICROCOMPUTER (IC800) TERMINALS

IC800 is utilizing an external ROM in its initial lot until using the mask item. As the contents of same terminals differ according to the lot for this reason, please be reminded at a time performing service. External ROM utilizing models are up to these serial numbers listed below.

Model	Serial No.	Model	Serial No.
EUROPE	~ 881, 886 ~ 950	CANADA	~ 130
U.K.	~ 300	Multi-Voltage	~ 100
U.S.A.	~ 620		

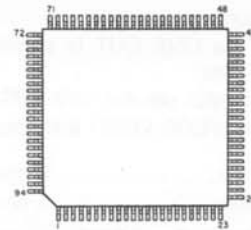

Terminal No.	Symbol Name	I/O	Terminal Function
1	CUEL2	O	CUE LED ON/OFF signal of CD-2. ON at "H".
2	PLYL2	O	PLAY LED ON/OFF signal of CD-2. ON at "H".
3	PITL2	O	PITCH LED ON/OFF signal of CD-2. ON at "H".
4	PITL1	O	PITCH LED ON/OFF signal of CD-1. ON at "H".
5	PLYL1	O	PLAY LED ON/OFF signal of CD-1. ON at "H".
6	CUEL1	O	CUE LED ON/OFF signal of CD-1. ON at "H".
7	RST-	I	Hard reset input. Reset at "L".
8	V _{DD}	—	+5V power supply.
9	X2	I	Clock oscilation circuit input 2.
10	X1	I	Clock oscilation circuit input 1.
11	V _{SS}	—	0V power supply.
12	V _{SS}	—	0V power supply.
13	—	—	Not connected.
14	LCE2	O	Chip enable signal of CD-2's LCD driver.
15	LCCLK2	O	Command transmitting clock for CD-2's LCD driver.
16	LDAT2	O	Command data for CD-2's LCD driver.
17	LCE1	O	Chip enable signal of CD-1's LCD driver.
18	LCCLK1	O	Command transmitting clock for CD-1's LCD driver.
19	LDAT1	O	Command data for CD-1's LCD driver.
20	—	O	Not used. Fixed to "L".
21	—	—	Not Connected.
22	—	O	Not used. Fixed to "L".
23	—	O	Not used. Fixed to "L".
24	—	O	Not used. Fixed to "L".
25	WR-	O	Not used. Mask item... fixed to "L", external ROM... fixed to "H".
26	OE-	O	Enable signal output for external ROM. Mask item... fixed to "L", external ROM... pulse output fot reading.
27	KOUT3	O	Key matrix scan signal 3.
28	KOUT2	O	Key matrix scan signal 2.
29	KOUT1	O	Key matrix scan signal 1.
30	KOUT0	O	Key matrix scan signal 0.
31	—	—	Not connected.
32	A15	O	Memory address 15. Not used. Mask item... fixed to "L".
33	A14	O	Memory address 14. Mask item... fixed to "L".
34	A13	O	Memory address 13. Mask item... fixed to "L".
35	—	—	Not connected.
36	A12	O	Memory address 12. Mask item... fixed to "L".
37	A11	O	Memory address 11. Mask item... fixed to "L".
38	A10	O	Memory address 10. Mask item... fixed to "L".
39	A9	O	Memory address 9. Mask item... fixed to "L".
40	A8	O	Memory address 8. Mask item... fixed to "L".
41	—	—	Not connected.

Terminal No.	Symbol Name	I/O	Terminal Function
42	AD7	I/O	Data bus 7. Mask item... fixed to "L".
43	AD6	I/O	Data bus 6. Mask item... fixed to "L".
44	AD5	I/O	Data bus 5. Mask item... fixed to "L".
45	AD4	I/O	Data bus 4. Mask item... fixed to "L".
46	AD3	I/O	Data bus 3. Mask item... fixed to "L".
47	AD2	I/O	Data bus 2. Mask item... fixed to "L".
48	AD1	I/O	Data bus 1. Mask item... fixed to "L".
49	AD0	I/O	Data bus 0. Mask item... fixed to "L".
50	ASTB	O	Pulse for address latch. Mask item... fixed to "L".
51	V _{SS}	—	0V power supply.
52	V _{SS}	—	0V power supply.
53	—	—	Not connected.
54	MODE	I	Memory mode selection terminal. Use external ROM at "H", use mask ROM at "L". Mask item... "L", external ROM "H".
55	—	—	Not connected.
56	—	I	Not used.
57	—	I	Not used.
58	—	I	Not used.
59	—	I	Not used.
60	—	—	Not connected.
61	—	I	Not used.
62	—	I	Not used.
63	—	I	Not used.
64	—	I	Not used.
65	V _{DD}	—	+5v power supply.
66	V _{DD}	—	+5v power supply.
67	PIT1	I	CD-1 pitch volume input.
68	PIT2	I	CD-2 pitch volume input.
69	—	I	Not used. Fixed to "L".
70	—	—	Not connected.
71	—	I	Not used. Fixed to "L".
72	—	I	Not used. Fixed to "L".
73	—	I	Not used. Fixed to "L".
74	—	I	Not used. Fixed to "L".
75	—	I	Not used. Fixed to "L".
76	AV _{DD}	—	+5v power supply for A/D converter.
77	AVREF1	—	+5V. A/D converter reference voltage.
78	—	—	Not connected.
79	AV _{SS}	—	0V power supply for A/D converter.
80	—	O	Not used.
81	—	O	Not used.
82	AVREF2	—	+5V. D/A converter reference voltage.
83	AVREF3	—	0V. D/A converter reference voltage.
84	—	—	Not connected.
85	KIN10	I	CD-1 key data 0.
86	KIN11	I	CD-1 key data 1.
87	KIN12	I	CD-1 key data 2.
88	KIN13	I	CD-1 key data 3.
89	KIN20	I	CD-2 key data 0.
90	KIN21	I	CD-2 key data 1.
91	KIN22	I	CD-2 key data 2.
92	KIN23	I	CD-2 key data 3.
93	RXD-	I	Serial interface reception data.
94	TXD-	O	Serial interface transmission data.

TABLE OF MICROCOMPUTER μ PD78233GJ-5BG(IC200) TERMINALS

IC200 is utilizing an external ROM in its initial lot until using the mask item. As the contents of some terminals differ according to the lot for this reason, please be reminded at a time performing service. External ROM utilizing models are up to these serial numbers listed below.

Model	Serial No.	Model	Serial No.
EUROPE	~ 881, 886 ~ 950	CANADA	~ 130
U.K.	~ 300	Multi-Voltage	~ 100
U.S.A.	~ 620		

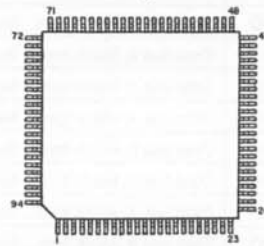

Terminal No.	Symbol Name	I/O	Terminal Function
1	—		
2	RST2	O	Reset signal of IC201(μ PD6381GF).
3	BRRQ	O	Break request signal of IC201(μ PD6381GF). Not used. Fixed to "H".
4	BRAK	I	Break acknowledge signal of IC201(μ PD6381GF). Not used. Fixed to "H".
5	GF	I	?
6	SO	I	IC201 serial data input.
7	RST-	I	Hard reset input. Reset at "L".
8	V _{DD}	—	+5V power supply.
9	X2	I	Clock oscillation circuit input 2.
10	X1	I	Clock oscillation circuit input 1.
11	V _{SS}	—	0V power supply.
12	V _{SS}	—	0V power supply.
13	—	—	Not connected.
14	CLOK	O	Clock for servo command, level command. Connected to IC1, IC300.
15	DATA	O	Data for servo command, level command. Connected to IC1, IC300.
16	XLAT	O	Latch pulse of servo command. Latched at falling edge.
17	—	O	Not used. Fixed to "L".
18	LDON	O	Laser ON/OFF signal of optical pickup. Laser emits light at "H".
19	—	O	Not used. Fixed to "L".
20	—	O	Not used. Fixed to "L".
21	—	—	Not connected.
22	—	O	Not used. Fixed to "L".
23	DRNO-	I	Mechanism number input. Mechanism 1 at "L", mechanism 2 at "H".
24	TXDEN	O	Demand signal of serial interface using. Used at "H".
25	—	O	Not used. Mask item — fixed to "L", external ROM — fixed to "H".
26	OE-	O	Output enable signal for external ROM. Mask item — fixed to "L", external ROM — pulse output for reading.
27	CS-	O	Chip select signal of IC201. Normally "H". "L" at select only.
28	C-/D	O	Command/data designate signal of IC201. Command at "L", indicates data transmitting mode at "H".
29	SCK-	O	Clock for command transmission to IC201.
30	SI	O	Command data to IC201.
31	—	—	Not connected.
32	A15	O	Memory address 15. Not used. Mask item — fixed to "L".
33	A14	O	Memory address 14. Mask item — fixed to "L".
34	A13	O	Memory address 13. Mask item — fixed to "L".
35	—	—	Not connected.
36	A12	O	Memory address 12. Mask item — fixed to "L".
37	A11	O	Memory address 11. Mask item — fixed to "L".
38	A10	O	Memory address 10. Mask item — fixed to "L".
39	A9	O	Memory address 9. Mask item — fixed to "L".
40	A8	O	Memory address 8. Mask item — fixed to "L".
41	—	—	Not connected.
42	AD7	I/O	Data bus 7. Mask item — fixed to "L".
43	AD6	I/O	Data bus 6. Mask item — fixed to "L".

Terminal No.	Symbol Name	I/O	Terminal Function
44	AD5	I/O	Data bus 5. Mask item — fixed to "L".
45	AD4	I/O	Data bus 4. Mask item — fixed to "L".
46	AD3	I/O	Data bus 3. Mask item — fixed to "L".
47	AD2	I/O	Data bus 2. Mask item — fixed to "L".
48	AD1	I/O	Data bus 1. Mask item — fixed to "L".
49	AD0	I/O	Data bus 0. Mask item — fixed to "L".
50	ASTB	O	Pulse for address latch. Mask item — fixed to "L". *
51	V _{SS}	—	0V power supply.
52	V _{SS}	—	0V power supply.
53	—	—	Not connected.
54	MODE	I	Memory read select terminal. External ROM use at "H", mask ROM use at "L". Mask item — "L", external ROM — "H".
55	—	—	Not connected.
56	AMUTE	O	Audio output mute signal. Mute at "H".
57	SQCK	O	Clock for sub—code reading.
58	SENS	I	Indication signal of servo actuating condition. Emits from IC2.
59	CLOSE—	I	Tray CLOSE switch. CLOSE state at "L".
60	—	—	Not connected.
61	OPEN—	I	Tray OPEN switch. OPEN state at "L".
62	SQSO	I	Sub—code data input. Emits from IC2.
63	DFLAT	O	Command latch pulse for digital filter. Output to IC300.
64	—	O	Not used. Fixed to "H".
65	V _{DD}	—	+5V power supply.
66	V _{DD}	—	+5V power supply.
67	LDIN	I	Analog input for tray drive servo.
68	STIN	I	Input for between microcomputers communication. Connected to STOUT of the other mechanism microcomputer. To communicate with 3 kinds of voltages, i.e. 0V, 2.5V, 5V.
69	—	I	Not used. Fixed to "L".
70	—	—	Not connected.
71	—	I	Not used. Fixed to "L".
72	—	I	Not used. Fixed to "L".
73	—	I	Not used. Fixed to "L".
74	—	I	Not used. Fixed to "L".
75	—	I	Not used. Fixed to "L".
76	AV _{DD}	—	+5V power supply for A/D converter.
77	AVREF1	—	+5V. A/D converter reference voltage.
78	—	—	Not connected.
79	AV _{SS}	—	0V power supply for A/D converter.
80	LOADER	O	Tray drive signal. Stops at 2.5V, CLOSE action at 3V, OPEN action at 2V.
81	STOUT	O	Output for microcomputer communication. Connects to STIN of the other microcomputer. Communicates with 3 kinds of voltages, i.e. 0V, 2.5V, 5V.
82	AVREF2	—	+5V. D/A converter reference voltage.
83	AVREF3	—	0V. D/A converter reference voltage.
84	—	—	Not connected.
85	—	I	Not used. Fixed to 0V.
86	EJSW—	I	EJECT/OPEN switch input. Connected to the switch of front panel. Shifts to "L" when the switch is pressed.
87	RST	I	Input for +5V voltage observation. Shifts to "H" when POWER switch is turned off.
88	WFCK	I	Connected to WFCK output of IC2. 7.35kHz clock.
89	SCOR	I	Sub-code sink input. Connect to IC2. Input 75 pulses per 1 second.
90	DRDY	I	Data receiving READY signal of IC201. Fixed to "H".
91	—	I	Not used. Fixed to "L".
92	OVF—	I	Over flag of IC201. Normally "H".
93	RXD—	I	Serial interface reception data.
94	TXD—	O	Serial interface transmission data.

TABLE OF DIGITAL SIGNAL PROCESSOR μ PD6381GF (IC201) TERMINALS

Terminal No.	Symbol Name	I/O	Terminal Function
1	DRDY	O	Command reception READY signal from microcomputer. Normally "H".
2	FSMASK	I	LRCK mask signal. Fixed to "L".
3	SEL	I	Clock input select. Fixed to "H".
4	—	I	Not used.
5	XO	O	X'tal oscillation output.
6	XI	I	X'tal oscillation input.
7	GND	—	0V power supply.
8	XFSO	O	Clock Output. Not used.
9	—	—	Not connected.
10	LRCKO	O	LR clock output. 44.1kHz.
11	WCLKO	O	Word clock output. 88.2kHz. Not used.
12	BCLKO	O	Bit clock output. 2.1MHz.
13	BRAK-	O	Break acknowledge output. Fixed to "H".
14	GND	—	0V power supply.
15	BRRQ-	I	Break request input. Fixed to "H".
16	FSRST-	I	Program counter reset input. Fixed to "H".
17	RST2-	I	Soft reset input. Normally "H".
18	RST-	I	Hard reset input. Normally "H".
19	A0	O	External RAM address 0.
20	A1	O	External RAM address 1.
21	A2	O	External RAM address 2.
22	A3	O	External RAM address 3.
23	A4	O	External RAM address 4.
24	A5	O	External RAM address 5.
25	A6	O	External RAM address 6.
26	A7	O	External RAM address 7.
27	A8	O	External RAM address 8.
28	A9	O	External RAM address 9. Not used.
29	A10	O	External RAM address 10. Not used.
30	A11	O	External RAM address 11. Not used.
31	A12	O	External RAM address 12. Not used.
32	A13	O	External RAM address 13. Not used.
33	V _{DD}	—	+5V power supply.
34	A14	O	External RAM address 14. Not used.
35	A15	O	External RAM address 15. Not used.
36	A16	O	External RAM address 16. Not used.
37	RAS-	O	External RAM low address strobe signal.
38	CAS-	O	External RAM column address strobe signal.
39	WE-	O	External RAM write enable signal.
40	I01	I/O	External RAM data 1.
41	I02	I/O	External RAM data 2.
42	I03	I/O	External RAM data 3.
43	I04	I/O	External RAM data 4.
44	I05	I/O	External RAM data 5. Not used.
45	I06	I/O	External RAM data 6. Not used.
46	I07	I/O	External RAM data 7. Not used.
47	I08	I/O	External RAM data 8. Not used.
48	I09	I/O	External RAM data 9. Not used.
49	I010	I/O	External RAM data 10. Not used.
50	I011	I/O	External RAM data 11. Not used.
51	I012	I/O	External RAM data 12. Not used.

Terminal No.	Symbol Name	I/O	Terminal Function
52	I013	I/O	External RAM data 13. Not used.
53	I014	I/O	External RAM data 14. Not used.
54	I015	I/O	External RAM data 15. Not used.
55	I016	I/O	External RAM data 16. Not used.
56	GND	—	0V power supply.
57	MD0	I	Mode select 0. Fixed to "L".
58	MD1	I	Mode select 1. Fixed to "H".
59	MD2	I	Mode select 2. Fixed to "L".
60	BCLK1	I	Bit clock input. 2.18MHz.
61	LRCK1	I	LR clock input. 44.1kHz.
62	BCLK2	I	Fixed to "L". Not used.
63	LRCK2	I	Fixed to "L". Not used.
64	DI1	I	Data input.
65	DO1	O	Data output.
66	DI2	I	Fixed to "L". Not used.
67	DO2	O	Not used.
68	DO3	O	Not used.
69	DORQ-	I	Not used. Fixed to "H".
70	GF-	O	G flag output. Normally "H".
71	OVF-	O	Over flag output. Normally "H".
72	V _{DD}	—	+5V power supply.
73	TEST0	I	Fixed to "H".
74	TEST1	I	Fixed to "H".
75	SETRDY	O	Not used.
76	SO	O	Serial data output.
77	SCK-	I	Serial data input/output clock.
78	SI	I	Serial data input.
79	C-/D	I	Command /data designation signal. "L" - command, "H" - data.
80	CS-	I	Chip select input.

CXD2500AQ Terminal Function

Terminal No.	Symbol	I/O		Terminal Function
1	FOK	I		Input terminal for OK focussing. Use for Servo-autosequencer.
2	FSW	O	Z,0	Output to shift time constant of output filter for spindle motor.
3	MON	O	1,0	ON/OFF control output for spindle motor.
4	MDP	O	1,Z,0	Servo control for spindle motor.
5	MDS	O	1,Z,0	Servo control for spindle motor.
6	LOCK	O	1,0	Sampling GFS by 460 Hz and if it is "H", delivers "H" ; if it is continuously "L" 8 times, delivers "L".
7	NC		—	
8	VCOO	O	1,0	Oscillation current output for analog EFM PLL.
9	VCOI	I		Oscillation current output for analog EFM PLL. f LOCK=8.6436MHz.
10	TEST	I		TEST output. Normally GND.
11	PDO	O	1,Z,0	Charge pump output for analog EFM PLL.
12	Vss			GND.
13	NC		—	
14	NC		—	
15	NC		—	
16	VPDO	O	1,Z,0	Charge pump output for variable pitch PLL.
17	VCKI	O		Clock input from external VCO for variable pitch. fc center=16.9344MHz.
18	FILO	O	Analog	Filter output for master PLL. (slave=digital PLL)
19	FILI	I		Filter input for master PLL.
20	PCO	O	1,Z,0	Charge pump output for master PLL.
21	AVss			Analog GND.
22	CLTV	I		Control voltage input for master VCO.
23	AVDD			Analog power supply (+5V).
24	RF	I		EFM signal input.
25	BIAS	I		Constant-current input for Asymmetry circuit.
26	ASYI	I		Compare voltage input for Asymmetry.
27	ASYO	O	1,0	Full swing output for EFM. (L=Vss, H=VDD).
28	ASYE	I		L: Asymmetry circuit → OFF. H: Asymmetry circuit → ON.
29	NC		—	
30	PSSL	I		Input to shift output mode of audio data. Serial output at L; parallel output at H.
31	WDCK	O	1,0	D/A Interface for 48 bit slot. Word-clock f=2 Fs.
32	LRCK	O	1,0	D/A Interface for 48 bit slot. LR-clock f= Fs.
33	VDD			Power supply (+5V).
34	DA16	O	1,0	At PSSL=1 for DA16 (MBS) output; PSSL=0 for serial data of 48 bit slot. (2s'COMP, MSB first).
35	DA15	O	1,0	At PSSL=1 for DA15 output; PSSL=0 for bit clock of 48 bit slot.
36	DA14	O	1,0	At PSSL=1 for DA14 output; PSSL=0 for serial data of 64 bit slot. (2s'COMP, LSB first).
37	DA13	O	1,0	At PSSL=1 for DA13 output; PSSL=0 for bit clock of 64 bit slot.
38	DA12	O	1,0	At PSSL=1 for DA12 output; PSSL=0 for LR clock of 64 bit slot.
39	DA11	O	1,0	At PSSL=1 for DA11 output; PSSL=0 for GTOPO output.
40	DA10	O	1,0	At PSSL=1 for DA10 output; PSSL=0 for XUGF output.
41	DA09	O	1,0	At PSSL=1 for DA09 output; PSSL=0 for XPLCK output.
42	DA08	O	1,0	At PSSL=1 for DA08 output; PSSL=0 for GFS output.
43	DA07	O	1,0	At PSSL=1 for DA07 output; PSSL=0 for RFCK output.
44	DA06	O	1,0	At PSSL=1 for DA06 output; PSSL=0 for C2PO output.
45	DA05	O	1,0	At PSSL=1 for DA05 output; PSSL=0 for XRAOF output.
46	DA04	O	1,0	At PSSL=1 for DA04 output; PSSL=0 for MNT3 output.
47	DA03	O	1,0	At PSSL=1 for DA03 output; PSSL=0 for MNT2 output.
48	DA02	O	1,0	At PSSL=1 for DA02 output; PSSL=0 for MNT1 output.
49	DA01	O	1,0	At PSSL=1 for DA01 output; PSSL=0 for MNT0 output.
50	APTR	O	1,0	Control output for aperture compensation. In H for R-ch.
51	APTL	O	1,0	Control output for aperture compensation. In H for L-ch.

Terminal No.	Symbol	I/O	Terminal Function
52	Vss		GND.
53	XTAI	I	X'tal oscillation circuit input. By selecting of mode, f=16.9344MHz or 33.8688MHz.
54	XTAO	O 1,0	X'tal oscillation circuit input. f=16.9344MHz.
55	XTSL	I	Selection input terminal of X'tal. "L" for X'tal 16.9344MHz; H for 33.8688MHz.
56	FSTT	O 1,0	2/3 Dividing output of 53 and 54 terminal. No change by variable pitch.
57	C4M	O 1,0	4.2336MHz output. When variable pitched, simultaneously changes.
58	C16M	O 1,0	16.9344MHz output. When variable pitched, simultaneously changes.
59	MD2	I	Digital-out ON/OFF control. ON at H; OFF at L.
60	DOUT	O 1,0	Digital-out output terminal.
61	EMPH	O 1,0	When playback disc emphasized, outputs H; otherwise outputs L.
62	WFCK	O 1,0	WFCK (Write Flame Clock) output.
63	SCOR	O 1,0	Output of subcode sync. S0+S1. H output when either one detected.
64	SBSO	O 1,0	Serial output of Sub P~W.
65	EXCK	I	Clock input for SBSO read-out.
66	SQSO	O 1,0	Output for Sub Q 80 bits and PCM peak level 16 bits.
67	SQCK	I	Clock input for SQSO read-out.
68	MUTE	I	Mute at H; remove mute at L.
69	SENS	— 1,Z,0	SENS output. Outputs to CPU.
70	XRST	I	System reset input. Resets at "L".
71	DATA	I	Input of serial data from CPU.
72	XLAT	I	Input for latch from CPU. Latches serial data at release.
73	VDD		Power supply (+5V).
74	CLOCK	I	Serial data transfer clock input from CPU.
75	SEIN	I	SENS input from SSP.
76	CNIN	I	Input of tracking pulse.
77	DATO	O 1,0	Serial data output to SSP.
78	XLTO	O 1,0	Serial data latch output to SSP.
79	CLKO	O 1,0	Serial data transfer clock output to SSP.
80	MIRR	I	Mirror signal input. Use for track jump for over 128 tracks, using autosequencer.

CXD2500AQ

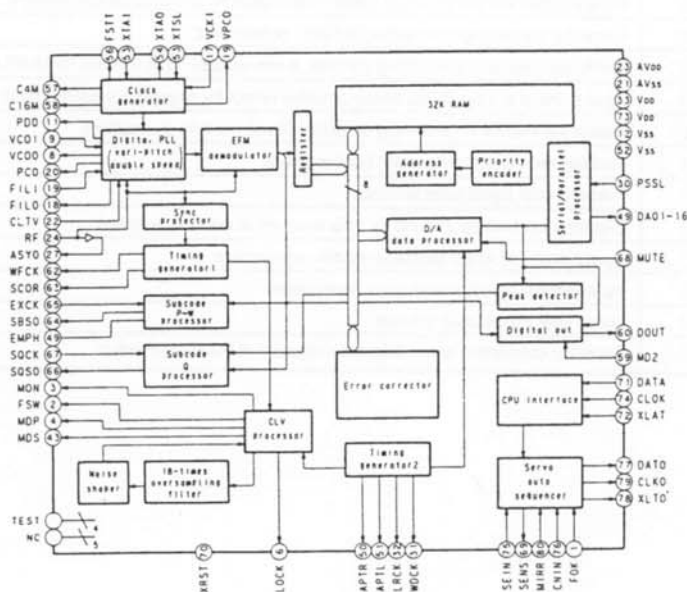

CXA1372Q Terminal Function

Terminal No.	Symbol	I/O	Terminal Function
1	Vc	I	Mid-point voltage input terminal.
2	FGD	I	In case of reducing higher range gain of focus servo, connect a capacitor between this terminal and terminal number (9).
3	FS3	I	Shifts higher range gain of focus servo by FS3 ON/OFF.
4	FLB	I	Terminal for external time constant to increase lower range of focus servo.
5	FEO	O	Focus drive output.
6	FE-	I	Reverse input terminal for focus amplifier.
7	SRCH	I	Terminal for external time constant to make focus search waveform.
8	TGU	I	Terminal for external time constant to shift higher range gain of tracking.
9	TG2	I	Terminal for external time constant to shift higher range gain of tracking.
10	TAO	O	Tracking drive output.
11	TA-	I	Reverse input terminal for tracking amplifier.
12	SL+	I	Non-reverse input terminal for sled amplifier.
13	SLO	O	Sled drive output.
14	SL-	I	Reverse input terminal for sled amplifier.
15	FSET	I	Terminal to compensate peak in focus/tracking phase.
17	ISET	I	Delivers a current to set the height of focus search, track jump, and sled kick.
18	SSTOP	I	Terminal for limit switch ON/OFF to detect disc innermost circle.
19	DIRC	I	Terminal is used at the time of 1 track jump. A 47 kohm pull up resistor is included.
20	LOCK	I	Reckless drive protection circuit of sled; activates at "L". A 47k ohm pull up resistor is included.
21	CLK	I	Serial data transfer clock input from CPU.
22	XLT	I	Latch input from CPU.
23	DATA	I	Serial data input from CPU.
24	XRST	I	Reset input terminal. Resets at "L".
26	C.OUT	O	Terminal to output signal for track number count.
27	SENS	O	Terminal to output FZC, AS, TZC, SSTOP by command from CPU.
29	MIRR	O	Output terminal for MIRR comparator.
30	DFCT	O	Output terminal for DEFECT comparator.
31	ASY	I	Input terminal for auto-symmetric control.
32	EFM	O	Output terminal for EFM comparator.
33	FOK	O	Output terminal for focus OK (FOK) comparator.
34	CC1	O	DEFECT bottom hold output terminal.
35	CC2	I	Input terminal to input DEFECT bottom hold output by capacitance combination.
37	CB	I	Capacitor connecting terminal for DEFECT bottom hold.
38	CP	I	MIRR hold capacitor connecting terminal. A non-reverse input terminal for MIRR comparator.
39	RFI	I	Input terminal to input RF summing amplifier output by capacitance combination.
40	RFO	O	Output terminal for RF summing amplifier. Check point for eye pattern.
42	TZC	I	Tracking zero-cross comparator input terminal.
43	TE	I	Tracking error signal input terminal.
44	TDFCT	I	Capacitor connecting terminal for time constant at the time of defect.
45	ATSC	I	Input terminal of ATSC detecting window comparator.
46	FZC	I	Input terminal of focus zero-cross comparator.
47	FE	I	Focus error signal input terminal.
48	FDFCT	I	Capacitor connecting terminal for time constant at the time of defect.

CXA1372Q

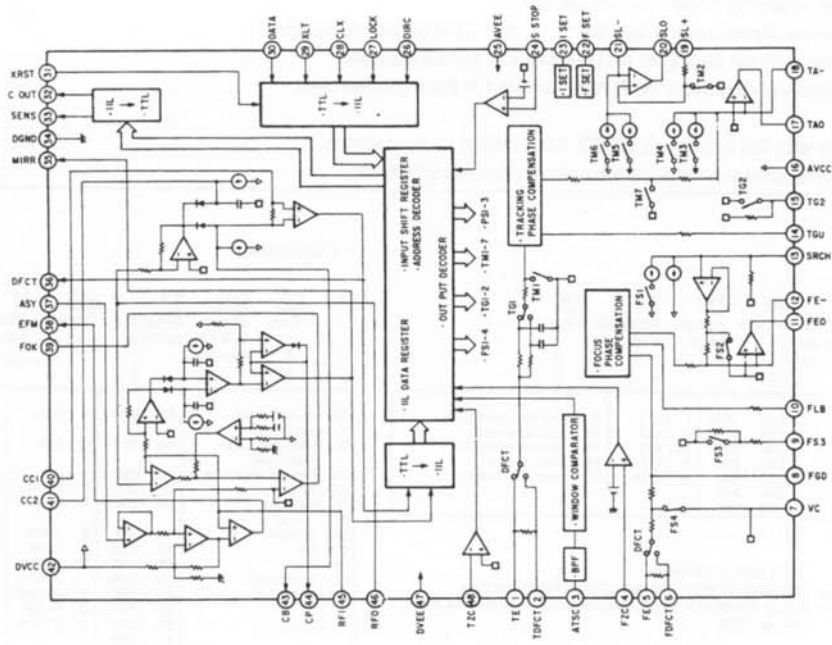

NOTE FOR PARTS LIST

- Part indicated with the mark "◎" are not always in stock and possibly to take a long period of time for supplying, or in some case supplying of part may be refused.
- When ordering of part, clearly indicate "1" and "I" (i) to avoid mis-supplying.
- Ordering part without stating its part number can not be supplied.
- Part indicated with the mark "★" is not illustrated in the exploded view.

WARNING:

Parts marked with this symbol  have critical characteristics.
Use ONLY replacement parts recommended by the manufacturer.

• Resistors

Ex.: RN 14K 2E 182 G FR
 Type Shape and performance Power Resistance Allowable error Others

RD : Carbon	2B : 1/8W	F : ±1%	P : Pulse-resistant type
RC : Composition	2E : 1/4W	G : ±2%	NL : Low noise type
RS : Metallic film	2H : 1/2W	J : ±5%	NB : Non-burning type
RW : Winding	3A : 1W	K : ±10%	FR : Fuse-resistor
RN : Metal film	3D : 2W	M : ±20%	F : Lead wire forming
RK : Metal mixture	3F : 3W		
	3H : 5W		

Resistance

1 8 2 ⇒ 1800 ohm = 1.8 kohm
 ↑ ↑ ↑
 Indicates number of zeros after effective number
 2-digit effective number, decimal point indicated by R.
 • Units: ohm

• Capacitors

Ex.: CE 04W 1H 2R2 M BP
 Type Shape and performance Dielectric strength Capacity Allowable error Others

CE : Aluminum foil electrolyte	0J : 6.3V	F : ±1%	HS : High stability type
CA : Aluminum solid electrolyte	1A : 10V	G : ±2%	BP : Non-polar type
CS : Tantalum electrolyte	1C : 16V	J : ±5%	HR : Ripple-resistant type
CO : Film	1E : 25V	K : ±10%	DL : For charge and discharge
CK : Ceramic	1V : 35V	M : ±20%	HF : For assuring high frequency
CC : Ceramic	1H : 50V	Z : +80%	U : UL part
CP : Oil	2A : 100V	Z : -20%	C : CSA part
CM : Mica	2B : 125V	P : +100%	W : UL-CSA type
CF : Metallized	2C : 160V	-0%	F : Lead wire forming
CH : Metallized	2D : 200V	C : ±0.25pF	
	2E : 250V	D : ±0.5pF	
	2H : 500V	= : Others	
	2J : 630V		

Capacity

2 R 2 ⇒ 2.2μF
 ↑ ↑ ↑
 1-digit effective number, decimal point indicated by R.
 2-digit effective number, decimal point indicated by R.
 • Units: μF, (for P, pF (μμF))
 • When the dielectric strength is indicated in AC, "AC" is included after

GU-2402 MAIN PWB UNIT

Ref No.	Part No.	Part Name	Remarks	Ref No.	Part No.	Part Name	Remarks
SEMICONDUCTORS GROUP							
IC700	263 0800 005	IC NJM78M05FA(S)		△	233 5955 006	POWER TRANS	Europe Model
IC701	263 0501 003	IC NJM79M05FA		△	233 5961 003	POWER TRANS	U.K. Model
IC702	263 0695 003	IC L780S05		△	233 5954 007	POWER TRANS	Multi- Voltage Model
IC703	262 1479 005	IC M5M34051P		△	212 4698 008	VOLTAGE SELECTOR	Multi- Voltage Model
IC710	268 0076 902	PROTECTOR ICP-N38					
IC711,712	268 0075 903	PROTECTOR ICP-N25					
IC713-715	268 0078 900	PROTECTOR ICP-N75	Multi- Voltage Model				
TR710,711	274 0160 907	Transistor 2SD2144STPU					
TR720,721	274 0160 907	Transistor 2SD2144STPU					
D700	276 0603 004	Diode MA750					
D702,703	276 0603 004	Diode MA750					
D704-707	276 0553 905	Diode 1SR35-200A					
D708-715	276 0432 903	Diode 1SS270A					
LE700	393 9462 017	LED SLR-40VC3F (RED)					
RESISTOR (Not included Carbon Film ±5% 1/4w)							
CAPACITORS GROUP							
C701	254 4255 720	Electrolytic 6800μF/16V	CE04W1C682MC(SME)				
C702,703	254 4255 717	Electrolytic 4700μF/16V	CE04W1C472MC(SME)				
C706	254 4254 941	Electrolytic 100μF/16V	CE04W1C101MT(SME)				
C708	253 9036 909	Ceramic 0.1μF/25V	CK45=1E104Z				
C710,711	253 4538 949	Ceramic 100pF/50V	CC45SL1H101J				
C712	253 9036 909	Ceramic 0.1μF/25V	CK45=1E104Z				
C720,721	253 4538 949	Ceramic 100pF/50V	CC45SL1H101J				
C722	253 9036 909	Ceramic 0.1μF/25V	CK45=1E104Z				
OTHERS PARTS GROUP							
L701-706	235 0049 900	BEADS INDUCTOR					
SW700,701	212 4763 904	TACT SWITCH(LONG ST)					
SW702	212 1039 000	1P PUSH SWITCH					
△F700	206 1039 018	FUSE 0.8A	U.S.A., Canada Model				
△F700	206 1031 032	FUSE 0.16A	Europe, U.K. Model				
△F700	206 1015 003	FUSE 0.5A	Multi- Voltage Model				
△	202 0040 909	FUSE CLIP					
CB700	205 0321 054	5P CONN.BASE(RED)					
△CB701,702	205 0581 001	2P VH CONN.BASE					
CB704	205 0190 052	5P NH CONN.BASE					
CB705	205 0717 008	8P MINI DIN CONN.BASE					
CB710	205 0668 047	21P FFC CONN.BASE					
CB711	204 8373 001	2P PIN JACK					
CB720	205 0668 047	21P FFC CONN.BASE					
CB721	204 8373 001	2P PIN JACK					
CC700	203 8196 034	5P KR-DS CONN.CORD					
CC706	203 4853 001	3P DS-DS CONN.CORD					
△	206 2086 002	AC CORD W/CONN.	U.S.A., Canada Model				
△	206 2089 009	AC CORD W/CONN.	Europe, U.K. Model				
△	206 2090 001	AC CORD W/CONN.	U.K. Model				
△	206 2088 000	AC CORD W/CONN.	Multi- Voltage Model				
△	233 5953 008	POWER TRANS	U.S.A., Canada Model				

**PRINTED WIRING BOARD PARTS LIST
GU-2403 CONTROL PWB UNIT**

Ref No.	Part No.	Part Name	Remarks	Ref No.	Part No.	Part Name	Remarks
SEMICONDUCTORS GROUP				RESISTORS GROUP (Not included Carbon Film ±5% 1/4W)			
IC800	262 1473 001	IC μPD78233GJ-5BG	U.S.A. Model Serial No.-620 Europe Model Serial No.-881 No.886-950 U.K. Model Serial No.-300 Canada Model Serial No.-130 Multi-Voltage Model Serial No.-100	R801	247 0005 905	Chip 100ohm 1/4W	RM73B-101J
IC800	262 1691 003	IC μPD 78234GJ-516-5BG	U.S.A. Model Serial No.621- Europe Model Serial No.882-885 No.951- U.K. Model Serial No.301- Canada Model Serial No.131- Multi-Voltage Model Serial No.101-	R802	247 0008 902	Chip 18Kohm 1/10W	RM73B-182J
IC801	262 1597 903	IC M5M34051FP		R804	247 0011 944	Chip 47Kohm 1/10W	RM73B-473J
IC802,803	263 0533 000	IC LC7582		R805	247 0011 944	Chip 47Kohm 1/10W	RM73B-473J
IC804	262 0943 901	IC HD74HC373FP-TL	U.S.A. Model Serial No.-620 Europe Model Serial No.-811 No.886-950 U.K. Model Serial No.-300 Canada Model Serial No.-130 Multi-Voltage Model Serial No.-100	R806,807	247 0007 945	Chip 1Kohm 1/10W	RM73B-102J
IC805	205 0488 010 GEN 2144	IC 28P IC SOCKET CONTROL ROM SUB Ass'Y	U.S.A. Model Serial No.-620 Europe Model Serial No.-881 No.886-950 U.K. Model Serial No.-300 Canada Model Serial No.-130 Multi-Voltage Model Serial No.-100	R810-813	247 0011 944	Chip 47Kohm 1/10W	RM73B-473J
IC806	262 1647 905	IC MN1382-S(TX)		R814	247 0011 957	Chip 51Kohm 1/10W	RM73B-513J
TR800-805	269 0082 902	Transistor DTC114EK		R815	247 0013 942	Chip 330Kohm 1/10W	RM73B-334J
D800,801	276 0438 949	Diode MA151WK		R816	247 0006 962	Chip 470ohm 1/10W	RM73B-471J
D802,803	276 0438 907	Diode MA151WA		R817,818	247 0005 989	Chip 220ohm 1/10W	RM73B-221J
D804-815	276 0438 910	Diode MA151A		R819,820	247 0003 965	Chip 27ohm 1/10W	RM73B-270J
LE810	393 9511 104	LED BACK LIGHT	(CD-1)	R823,824	247 0003 965	Chip 27ohm 1/10W	RM73B-270J
LE811	393 9462 017	LED SLR-40VC3F(RED)	CUE Monitor(CD-1)	R830-833	247 0011 944	Chip 47Kohm 1/10W	RM73B-473J
LE812,813	393 9512 006	LED SLR-40MC3F (GRN)	PLAY/PAUSE,PITCH Monitor (CD-1)	R834	247 0011 957	Chip 51Kohm 1/10W	RM73B-513J
LE830	393 9511 104	LED BACK LIGHT	(CD-2)	R835	247 0013 942	Chip 330Kohm 1/10W	RM73B-334J
LE831	393 9462 017	LED SLR-40VC3F(RED)	CUE Monitor(CD-2)	R836	247 0006 962	Chip 470ohm 1/10W	RM73B-471J
LE832,833	393 9512 006	LED SLR-40MC(GRN)	PLAY/PAUSE,PITCH Monitor (CD-2)	R837,838	247 0005 989	Chip 220ohm 1/10W	RM73B-221J
LC810	393 4139 002	LCD		R839,840	247 0003 965	Chip 27ohm 1/10W	RM73B-270J
LC830	393 4139 002	LCD		VR810	211 0763 015	Slide Volume	
				VR830	211 0763 015	Slide Volume	
CAPACITORS GROUP				OTHERS PARTS GROUP			
C800	257 0014 935	Ceramic-chip 0.1μF/25V	CK73F1E104Z	X800	399 0038 008	Ceramic Vibrator	CST12.0M
C801	254 4260 980	Electrolytic 10μF/50V	CE04W1H100M(SME)	SW811-822	212 4763 904	TACT SWITCH (LONG ST)	
C810,811	257 0014 935	Ceramic-chip 0.1μF/25V	CK73F1E104Z	SW830-841	212 4763 904	TACT SWITCH (LONG ST)	
C812	257 0006 969	Ceramic-chip 680pF/50V	CC73SL1H681J	L801-806	235 0049 900	BEADS INDUCTOR	
C830,831	257 0014 935	Ceramic-chip 0.1μF/25V	CK73F1E104Z	CB800,801	205 0708 020	18P CONN.SOCKET	
C832	257 0006 969	Ceramic-chip 680pF/50V	CC73SL1H681J	CB802	205 0717 008	8P MINI DIN CONN.BASE	
C842,843	257 0014 935	Ceramic-chip 0.1μF/25V	CK73F1E104Z	CB810	205 0707 021	18P CONN.BASE	
C861-865	257 0014 935	Ceramic-chip 0.1μF/25V	CK73F1E104Z	CB830	205 0707 021	18P CONN.BASE	

GU-2401 MECHA PWB UNIT

Ref No.	Part No.	Part Name	Remarks	Ref No.	Part No.	Part Name	Remarks
SEMICONDUCTORS GROUP							
IC001	262 1342 006	IC CXA1372Q(48PQFP)		R023	247 0012 930	Chip 110Kohm 1/10W	RM73B--114J
IC002	262 1514 009	IC CXD2500AQ		R024,025	247 0009 985	Chip 10Kohm 1/10W	RM73B--103J
IC003	262 1344 907	IC SN74LS624NSR		R026	247 0011 960	Chip 56Kohm 1/10W	RM73B--563J
IC004,005	263 0615 902	IC BA15218F		R027	247 0011 928	Chip 39Kohm 1/10W	RM73B--393J
IC006	263 0805 903	IC BA6296FP		R028	247 0009 956	Chip 7.5Kohm 1/10W	RM73B--752J
IC008	262 1205 907	IC TC74HCU04AF		R030	247 0012 927	Chip 100Kohm 1/10W	RM73B--104J
IC200	262 1473 001	IC UPD78233GJ-5BG	U.S.A. Model Serial No.--620 Europe Model Serial No.--881 No.886--950 U.K. Model Serial No.--300 Canada Model Serial No.--130 Multi-Voltage Model Serial No.--100	R031	247 0009 985	Chip 10Kohm 1/10W	RM73B--103J
				R034	247 0012 943	Chip 120Kohm 1/10W	RM73B--124J
				R038	247 0012 927	Chip 100Kohm 1/10W	RM73B--104J
				R039	247 0012 914	Chip 91Kohm 1/10W	RM73B--913J
				R040	247 0011 944	Chip 47Kohm 1/10W	RM73B--473J
				R043	247 0011 986	Chip 68Kohm 1/10W	RM73B--683J
				R044	247 0009 969	Chip 8.2Kohm 1/10W	RM73B--822J
				R045	247 0014 925	Chip 680Kohm 1/10W	RM73B--684J
IC200	262 1690 004	IC μ PD78234GJ-515-5BG	U.S.A. Model Serial No.621-- Europe Model Serial No.882--885 No.951-- U.K. Model Serial No.301-- Canada Model Serial No.131-- Multi-Voltage Model Serial No.101--	R046	247 0009 985	Chip 10Kohm 1/10W	RM73B--103J
				R047	247 0012 943	Chip 120Kohm 1/10W	RM73B--124J
				R050,051	247 0009 985	Chip 10Kohm 1/10W	RM73B--103J
				R052	247 0011 944	Chip 47Kohm 1/10W	RM73B--473J
				R053	247 0009 956	Chip 7.5Kohm 1/10W	RM73B--752J
				R054	247 0008 931	Chip 2.4Kohm 1/10W	RM73B--242J
				R055	247 0011 944	Chip 47Kohm 1/10W	RM73B--473J
				R056	247 0011 944	Chip 47Kohm 1/10W	RM73B--473J
				R057	247 0012 914	Chip 91Kohm 1/10W	RM73B--913J
IC201	262 1474 000	IC UPD6381GF		R059	247 0005 989	Chip 220ohm 1/10W	RM73B--221J
IC203	262 1615 908	IC V53C104BK		R060	247 0009 901	Chip 4.7Kohm 1/10W	RM73B--472J
IC204	262 0943 901	IC HD74HC373FP-TL	U.S.A. Model Serial No.--620 Europe Model Serial No.--881 No.886--950 U.K. Model Serial No.--300 Canada Model Serial No.--130 Multi-Voltage Model Serial No.--100	R061	247 0006 962	Chip 470ohm 1/10W	RM73B--471J
				R062	247 0011 902	Chip 33Kohm 1/10W	RM73B--333J
				R063	247 0009 985	Chip 10Kohm 1/10W	RM73B--103J
				R064	247 0008 960	Chip 3.3Kohm 1/10W	RM73B--332J
				R065	247 0009 943	Chip 6.8Kohm 1/10W	RM73B--682J
				R066	247 0009 985	Chip 10Kohm 1/10W	RM73B--103J
				R067	247 0009 985	Chip 10Kohm 1/10W	RM73B--103J
				R068	247 0010 929	Chip 15Kohm 1/10W	RM73B--153J
				R069	247 0010 916	Chip 13Kohm 1/10W	RM73B--133J
IC205	205 0488 010 GEN 2172	IC 28P IC SOCKET MECHA ROM SUB Ass'y	U.S.A. Model Serial No.--620 Europe Model Serial No.--881 No.886--950 U.K. Model Serial No.--300 Canada Model Serial No.--130 Multi-Voltage Model Serial No.--100	R079	244 2051 945	Metallic 1ohm 1W	RS14B3A010JNB ST(S)
				R080-083	247 0009 985	Chip 10Kohm 1/10W	RM73B--103J
				R084	247 0009 985	Chip 10Kohm 1/10W	U.S.A. Model Serial No.--620 Europe Model Serial No.--881 No.886--950 U.K. Model Serial No.--300 Canada Model Serial No.--130 Multi-Voltage Model Serial No.--100
IC300	262 1664 904	IC CXD2554M					
IC301,302	262 1409 004	IC PCM61P-L					
IC303,304	263 0615 902	IC BA15218F					
IC500	262 1647 905	IC MN1382-S(TX)					
TR070	274 0036 905	Transistor 2SD468(C)TF		R200	247 0009 985	Chip 10Kohm 1/10W	RM73B--103J
TR071	272 0025 907	Transistor 2SB562(C)TF		R202	247 0009 985	Chip 10Kohm 1/10W	RM73B--103J
TR300	269 0083 901	Transistor DTA114EK		R203	247 0009 985	Chip 10Kohm 1/10W	RM73B--103J
TR301	269 0082 902	Transistor DTC114EK		R205	247 0009 985	Chip 10Kohm 1/10W	RM73B--103J
				R250	247 0008 902	Chip 1.8Kohm 1/10W	RM73B--182J
				R303	247 0018 905	Chip 0ohm Jumper	RM73B--0R0K
D400	276 0533 909	Diode MA3047-TX		R304	247 0007 945	Chip 1Kohm 1/10W	RM73B--102J
				R305,306	247 0007 945	Chip 1Kohm 1/10W	RM73B--102J
RESISTORS GROUP (Not included Carbon Film \pm5% 1/4W)				R310	247 0011 944	Chip 47Kohm 1/10W	RM73B--473J
R020	247 0010 987	Chip 27Kohm 1/10W	RM73B--273J	R311	247 0014 967	Chip 1Mohm 1/10W	RM73B--105J
R021	247 0012 927	Chip 100Kohm 1/10W	RM73B--104J	R312	247 0013 984	Chip 470Kohm 1/10W	RM73B--474J
R022	247 0009 985	Chip 10Kohm 1/10W	RM73B--103J	R313	247 0012 998	Chip 200Kohm 1/10W	RM73B--204J
				R314	247 0009 998	Chip 11Kohm 1/10W	RM73B--113J

Ref No.	Part No.	Part Name	Remarks
R315	247 0009 927	Chip 5.6Kohm 1/10W	RM73B--562J
R316	247 0009 998	Chip 11Kohm 1/10W	RM73B--113J
R317	247 0010 945	Chip 18Kohm 1/10W	RM73B--183J
R318	247 0010 958	Chip 20Kohm 1/10W	RM73B--203J
R319	247 0010 990	Chip 30Kohm 1/10W	RM73B--303J
R330	247 0011 944	Chip 47Kohm 1/10W	RM73B--473J
R331	247 0014 967	Chip 1Mohm 1/10W	RM73B--105J
R332	247 0013 984	Chip 470Kohm 1/10W	RM73B--474J
R333	247 0012 998	Chip 200Kohm 1/10W	RM73B--204J
R334	247 0009 998	Chip 11Kohm 1/10W	RM73B--113J
R335	247 0009 927	Chip 5.6Kohm 1/10W	RM73B--562J
R336	247 0009 998	Chip 11Kohm 1/10W	RM73B--113J
R337	247 0010 945	Chip 18Kohm 1/10W	RM73B--183J
R338	247 0010 958	Chip 20Kohm 1/10W	RM73B--203J
R339	247 0010 990	Chip 30Kohm 1/10W	RM73B--303J
R350	247 0007 945	Chip 1Kohm 1/10W	RM73B--102J
R351	247 0008 960	Chip 3.3Kohm 1/10W	RM73B--332J
R402	247 0012 969	Chip 150Kohm 1/10W	RM73B--154J
R500,501	247 0011 902	Chip 33Kohm 1/10W	RM73B--333J
R502,503	247 0009 985	Chip 10Kohm 1/10W	RM73B--103J
R600	247 0012 927	Chip 100Kohm 1/10W	RM73B--104J
R601,602	247 0012 927	Chip 100Kohm 1/10W	RM73B--104J
R603	247 0009 985	Chip 10Kohm 1/10W	RM73B--103J
R607	247 0012 927	Chip 100Kohm 1/10W	RM73B--104J
R608	247 0009 901	Chip 4.7Kohm 1/10W	RM73B--472J
R609	247 0012 927	Chip 100Kohm 1/10W	RM73B--104J
R700	247 0009 998	Chip 11Kohm 1/10W	RM73B--113J
R701	247 0008 915	Chip 2Kohm 1/10W	RM73B--202J
R702	247 0006 917	Chip 300ohm 1/10W	RM73B--301J
R703	247 0007 945	Chip 1Kohm 1/10W	RM73B--102J
R704	247 0012 927	Chip 100Kohm 1/10W	RM73B--104J
VR001,002	211 6086 903	Semi Fixed Resistor 22Kohm	V04PB203M(RVG4M)
VR300,301	211 6077 938	Semi Fixed Resistor 100Kohm	V06PB104
CAPACITORS GROUP			
C001	254 4430 008	Electrolytic 1000µF/6.3V	CE04W0J102M(KMG)
C002	257 0014 935	Ceramic-chip 0.1µF/25V	CK73F1E104Z
C010	257 0010 900	Ceramic-chip 0.01µF/50V	CK73B1H103K
C011	257 0009 937	Ceramic-chip 2700pF/50V	CK73B1H272K
C012	257 0010 900	Ceramic-chip 0.01µF/50V	CK73B1H103K
C013	257 1010 941	Ceramic-chip 3300pF/50V	CK73B1H332K
C014	257 0006 943	Ceramic-chip 560pF/50V	CC73SL1H561J
C015	257 1013 951	Ceramic-chip 0.047µF/25V	CK73B1E473K
C016	257 1013 993	Ceramic-chip 0.1µF/25V	CK73B1E104K
C017	257 1013 951	Ceramic-chip 0.047µF/25V	CK73B1E473K
C018	257 0009 924	Ceramic-chip 2200pF/50V	CK73B1H222K
C019	257 1013 993	Ceramic-chip 0.1µF/25V	CK73B1E104K
C020	257 1013 980	Ceramic-chip 0.082µF/25V	CK73B1E823K
C021	257 1011 966	Ceramic-chip 0.033µF/50V	CK73B1H333K
C022	257 0004 961	Ceramic-chip 100pF/50V	CC73SL1H101J
C024	254 4304 930	Electrolytic 6.8µF/35V	CE04W1V6R8M(SRE)
C025	256 1035 910	Metallize 0.22µF/50V	CF93A1H224J
C026	257 0003 991	Ceramic-chip 51pF/50V	CC73SL1H510J
C027	257 1013 993	Ceramic-chip 0.1µF/25V	CK73B1E104K
C028	254 4304 927	Electrolytic 4.7µF/35V	CE04W1V4R7M(SRE)

Ref No.	Part No.	Part Name	Remarks
C029	257 0004 961	Ceramic-chip 100pF/50V	CC73SL1H101J
C030,031	257 0012 966	Ceramic-chip 0.01µF/50V	CK73F1H103Z
C032	254 4305 926	Electrolytic 0.22µF/50V	CE04W1HR22M(SRE)
C033	257 1011 966	Ceramic-chip 0.033µF/50V	CK73B1H333K
C040,041	257 0014 935	Ceramic-chip 0.1µF/25V	CK73F1E104Z
C044	257 0010 900	Ceramic-chip 0.01µF/50V	CK73B1H103K
C045	254 4299 964	Electrolytic 47µF/16V	CE04W1C470M(SRE)
C046	257 0014 935	Ceramic-chip 0.1µF/25V	CK73F1E104Z
C051	257 0004 961	Ceramic-chip 100µF/50V	CC73SL1H101J
C060	254 4305 926	Electrolytic 0.22µF/50V	CE04W1HR22M(SRE)
C061	257 0002 989	Ceramic-chip 18pF/50V	CC73SL1H180J
C062	257 1013 951	Ceramic-chip 0.047µF/25V	CK73B1E473K
C063	257 0007 942	Ceramic-chip 1500pF/50V	CC73SL1H152J
C064	257 0001 951	Ceramic-chip 3pF/50V	CC73SL1H3ROC
C065	257 0001 977	Ceramic-chip 5pF/50V	CC73SL1H5ROC
C066	254 4300 963	Electrolytic 100µF/6.3V	CE04W0J101M(SRE)
C067-069	257 0014 935	Ceramic-chip 0.1µF/25V	CK73F1E104Z
C104	257 0014 935	Ceramic-chip 0.1µF/25V	CK73F1E104Z
C200,201	257 0003 904	Ceramic-chip 22pF/50V	CC73SL1H220J
C202,203	257 0014 935	Ceramic-chip 0.1µF/25V	CK73F1E104Z
C205	257 0014 935	Ceramic-chip 0.1µF/25V	CK73F1E104Z
C206,207	254 4300 963	Electrolytic 100µF/6.3V	CE04W0J101M(SRE)
C253	254 4300 934	Electrolytic 22µF/6.3V	CE04W0J220M(SRE)
C300	257 0014 935	Ceramic-chip 0.1µF/25V	CK73F1E104Z
C301	254 4300 963	Electrolytic 100µF/6.3V	CE04W0J101M(SRE)
C302	257 0014 935	Ceramic-chip 0.1µF/25V	CK73F1E104Z
C303	254 4300 963	Electrolytic 100µF/6.3V	CE04W0J101M(SRE)
C304	257 0014 935	Ceramic-chip 0.1µF/25V	CK73F1E104Z
C305,306	257 0014 935	Ceramic-chip 0.1µF/25V	CK73F1E104Z
C307	257 0014 935	Ceramic-chip 0.1µF/25V	CK73F1E104Z
C308,309	257 0014 935	Ceramic-chip 0.1µF/25V	CK73F1E104Z
C310,311	257 0014 935	Ceramic-chip 0.1µF/25V	CK73F1E104Z
C312	257 0007 926	Ceramic-chip 1200pF/50V	CC73SL1H122J
C313	257 0005 931	Ceramic-chip 200pF/50V	CC73SL1H201J
C314	257 0002 992	Ceramic-chip 20pF/50V	CC73SL1H200J
C315	254 4306 925	Electrolytic 10µF/50V	CE04W1H100M(SRE)
C330,331	257 0014 935	Ceramic-chip 0.1µF/25V	CK73F1E104Z
C332	257 0007 926	Ceramic-chip 1200pF/50V	CC73SL1H122J
C333	257 0005 931	Ceramic-chip 200pF/50V	CC73SL1H201J
C334	257 0002 992	Ceramic-chip 20pF/50V	CC73SL1H200J
C335	254 4306 925	Electrolytic 10µF/50V	CE04W1H100M(SRE)
C401	257 0004 961	Ceramic-chip 100pF/50V	CC73SL1H101J
C500-505	257 0014 935	Ceramic-chip 0.1µF/25V	CK73F1E104Z
C700	257 0013 907	Ceramic-chip 0.047µF/50V	CK73F1H473Z
OTHERS PARTS GROUP			
X001	399 0036 013	CRYSTAL	16.9344MHz
X200	399 0038 008	CERAMIC VIBRATOR	CST12.0M
X201	399 0174 001	CRYSTAL	24.576MHz
CB001	205 0681 008	12P FFC SIDE BASE	
CB002	205 0395 051	5P CONN.BASE (RED) L	
CB003	205 0355 059	5P KR CONN.BASE(L)	
CB004	205 0702 039	21P FFC CONN.BASE(L)	
TP001	205 0355 062	6P KR CONN. BASE(L)	
	009 0079 009	21P FFC	

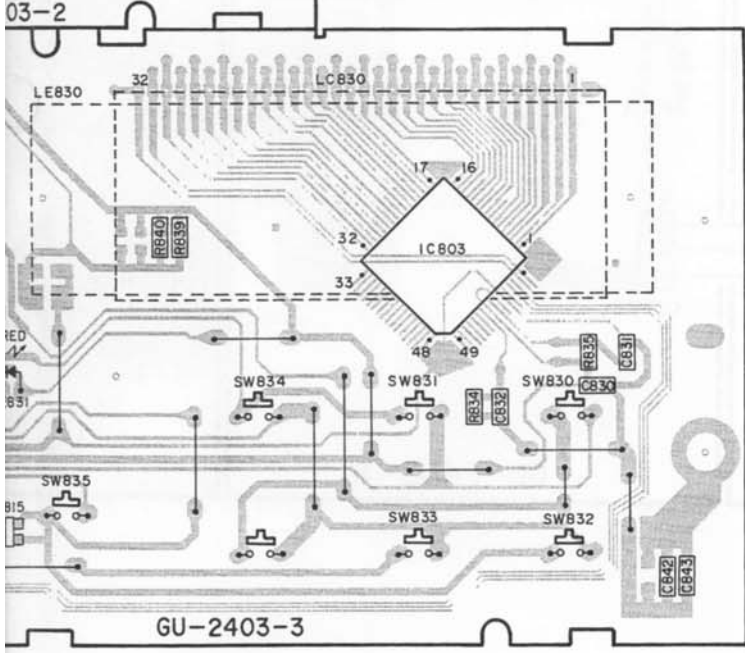
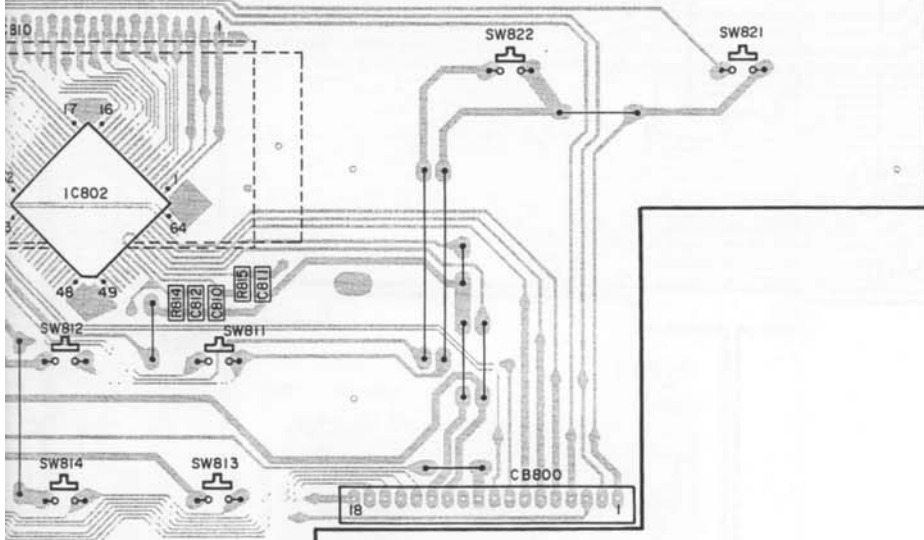
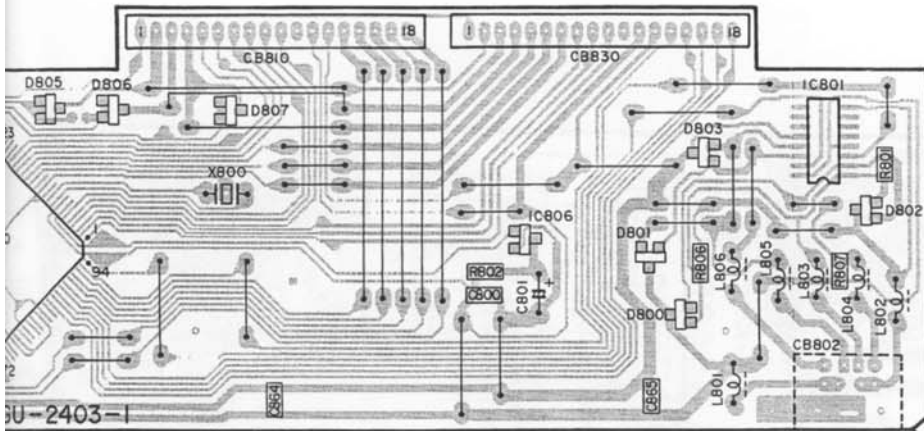

GU-2402 MAIN UNIT

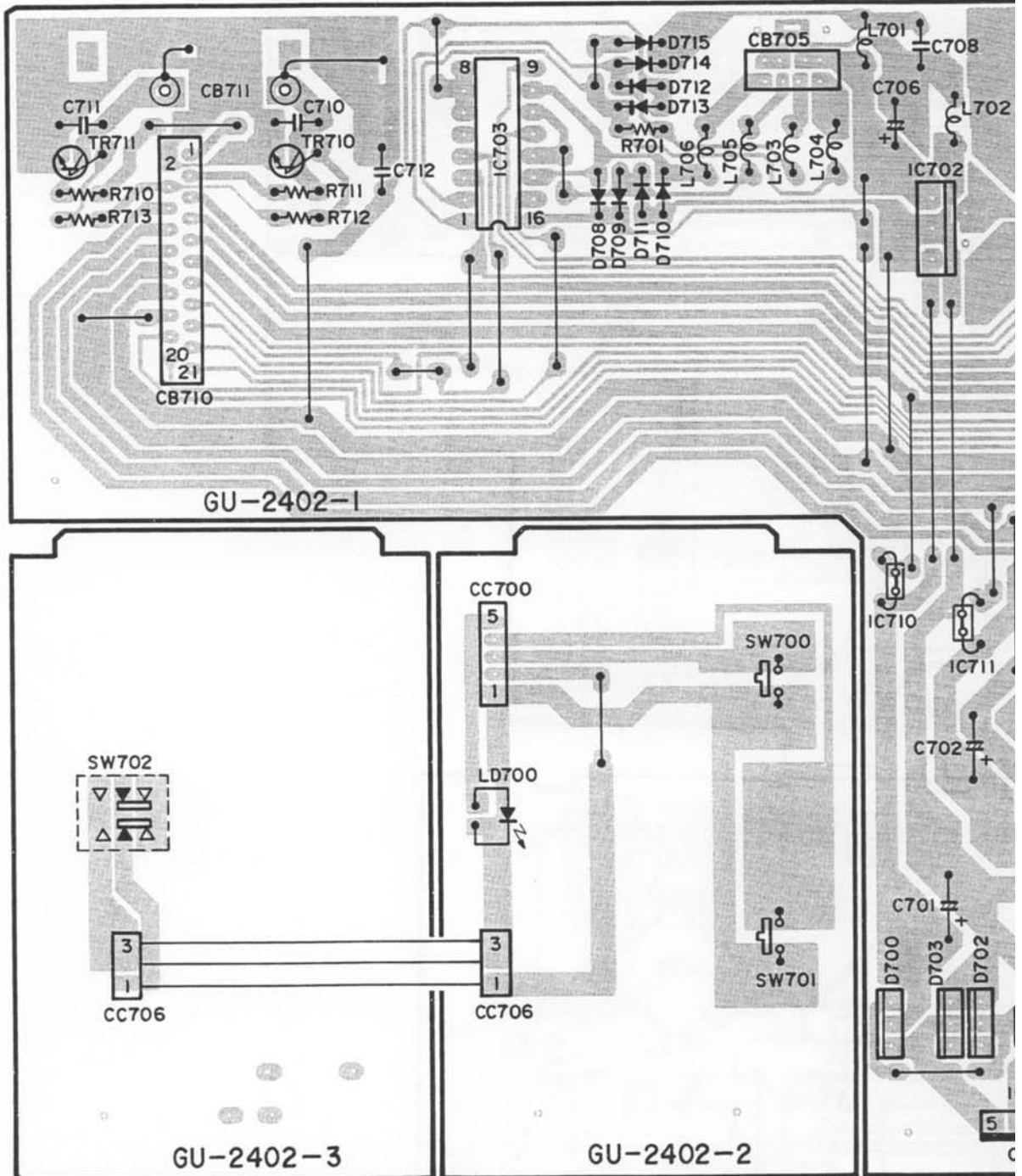

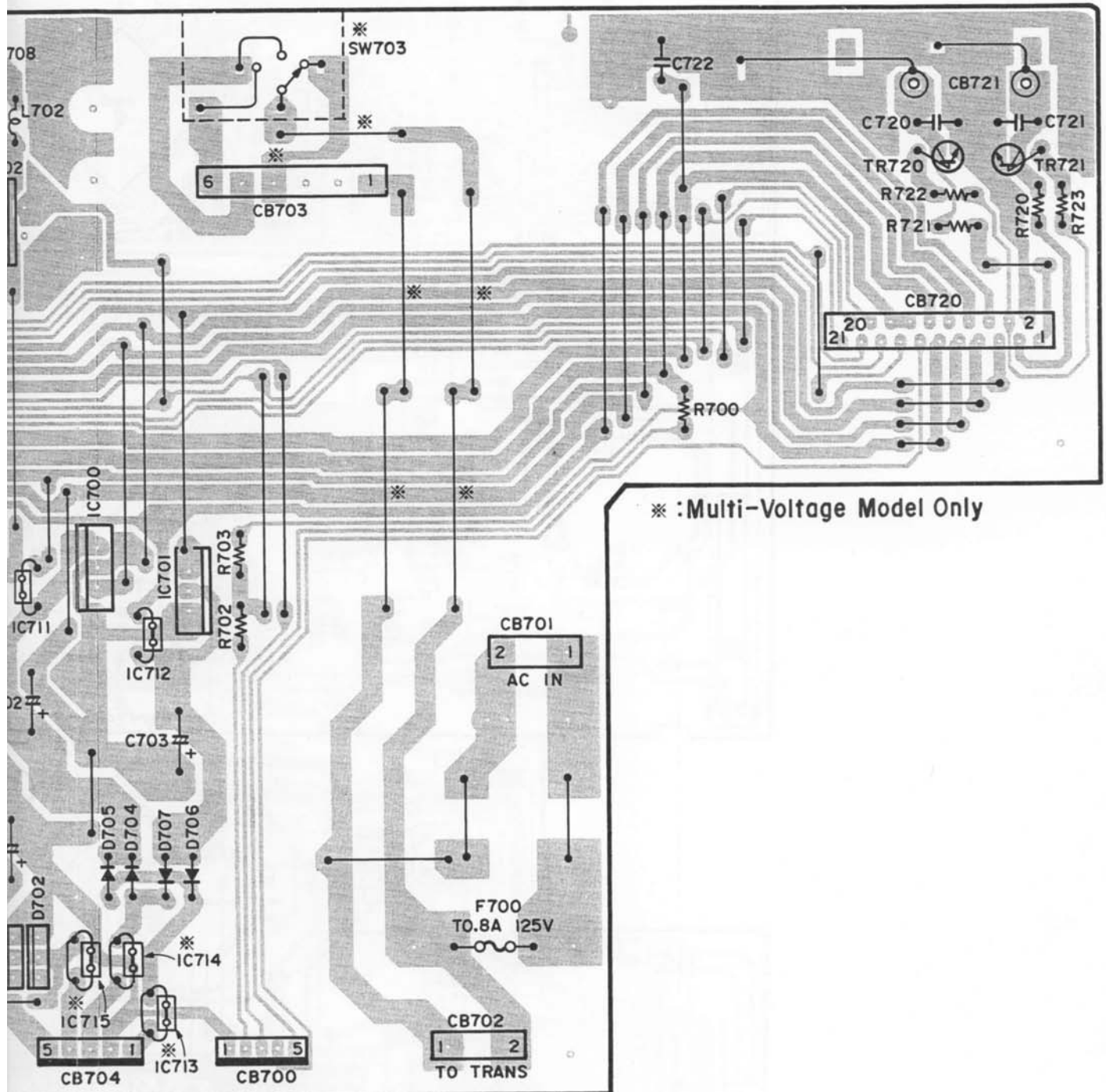

* : Multi-Voltage Model Only

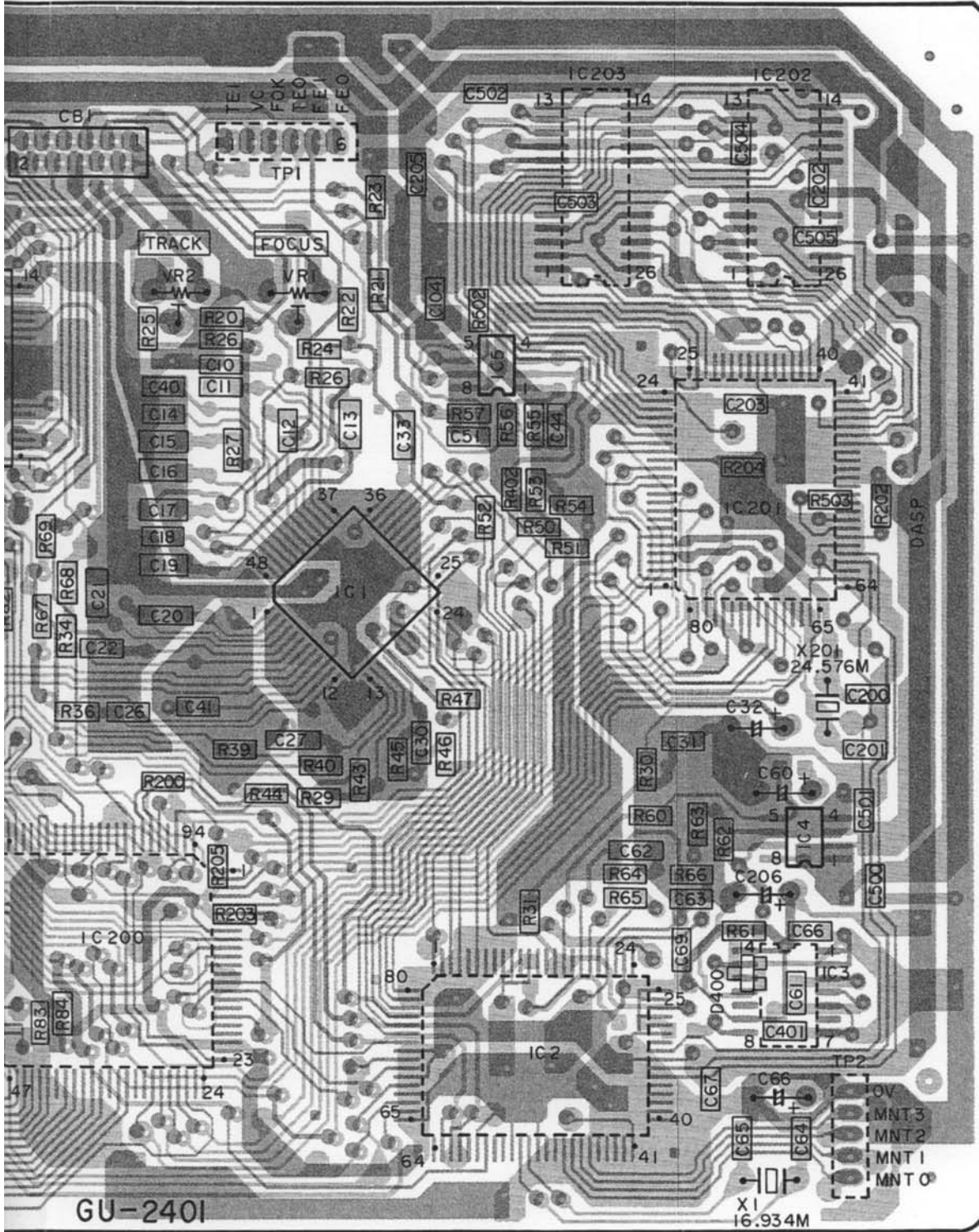

GU-2401

X1
16.934M

PARTS LIST OF EXPLODED VIEW

**PACKING AND ACCESSORIES
(not included EXPLODED VIEW)**

Ref. No.	Part No.	Part Name	Remarks	Q'ty
1	GU-2402	MAIN PWB UNIT		1
1-1	GU-2402-1	MAIN PWB UNIT		1
1-2	GU-2402-2	PANEL PWB UNIT		1
1-3	GU-2402-3	PANEL PWB UNIT		2
2	205 0717 008	8P MINI DIN CON. BASE		1
3	204 8373 001	2P PIN JACK		2
4	417 0462 105	HEAT SINK		1
5	206 1039 018	FUSE 0.8A	U.S.A. And Canada Model	1
6	206 1031 032	FUSE 0.16A	Europe And U.K.Model	1
7	206 1015 003	FUSE 0.5A	Multi-Voltage Model	1
8	212 4763 904	TACT SWITCH (LONG ST)		2
9	393 9462 017	LED (RED)	SLR-40VC3F	1
10	212 1039 000	1P PUSH SWITCH		1
11	144 2189 106	FRONT PANEL Ass'y		1
12	146 1371 005	LED WINDOW		1
13	411 1422 201	CHASSIS		1
14	499 0074 008	LOCKING CARD SPACER		2
15	461 0706 101	FOOT SHEET		2
16	105 1029 000	BACK PANEL	U.S.A. And Canada Model	1
17	105 1029 123	BACK PANEL	Europe Model	1
18	105 1029 123	BACK PANEL	U.K. Model	1
19	105 1029 110	BACK PANEL	Multi-Voltage Model	1
20	FG- 50	CD MECHA.UNIT		2
21	412 3495 200	P.W.B. BASE		2
22	499 0063 006	PIERCE HOLD		4
23	449 0033 049	LOCKING CARD SPACER		4
24	GU- 2401	MECHA PWB UNIT		1
25	009 0079 009	21P FFC		2
26	WA- 0120 H	WASHER		2
27	449 0077 005	CARD SPACER		2
28	412 3555 108	EARTH PLATE		1
29	461 0740 002	SHEET		2
30	206 2086 002	AC CORD W/CON.	U.S.A. And Canada Model	1
31	206 2089 009	AC CORD W/CON.	Europe Model	1
32	206 2090 001	AC CORD W/CON.	U.K. Model	1
33	206 2088 000	AC CORD W/CON.	Multi-Voltage Model	1
34	445 0056 008	CORD BUSH		1
35	233 5953 008	POWER TRANS	U.S.A. And Canada Model	1
36	233 5955 006	POWER TRANS	Europe Model	1
37	233 5961 003	POWER TRANS	U.K. Model	1
38	233 5954 007	POWER TRANS	Multi-Voltage Model	1
39	119 0069 109	RUBBER BUTTON (B)		1
40	113 1357 207	POWER SW.BUTTON		1
41	146 9238 140	LOADER PANEL		2
42	102 0425 101	TOP COVER		1
43	212 4698 008	VOLTAGE SELECTOR	Multi-Voltage Model	1
44	411 1143 001	SELECTOR BRACKET	Multi-Voltage Model	1
SCREWS				
101	473 7015 005	TAPPING SCREW 3x6 (S)	Black	11
102	473 7002 005	TAPPING SCREW 3x6 (S)		10
103	473 7508 017	TAPPING SCREW 3x10(P)	Black	7
104	473 7004 003	TAPPING SCREW 4x8 (S)		2
105	477 0263 005	3P SWELLING SCREW	Black	4

Ref. No.	Part No.	Part Name	Remarks	Q'ty
301	505 0061 010	ENVELOPE		1
302	511 2322 105	INST.MANUAL	U.S.A. Model	1
			U.K. Model	
			Multi-Voltage Model	
303	511 2347 106	INST.MANUAL	Canada And Europe Model	1
304	515 0474 002	DAI WARRANTY ROM	U.S.A. Model	1
305	515 0436 008	DCI WARRANTY	Canada Model	1
306	204 2518 008	8P MD.CORD		1
307	203 6305 007	2P PIN CORD		2
308	505 0102 092	STYRENE PAPER		1
309	505 0099 008	POLY COVER		1
310	505 0099 082	POLY COVER		1
311	412 3556 000	CONNECTING BRACKET		2
312	477 0053 040	WASHER		8
313	471 3505 021	SCREW 5x10		8
314	503 1001 206	CUSHION		2
315	RC-35	REMOTE CONTROL UNIT		1
316	505 1012 021	STYRENE PAPER		1
317	503 1010 103	CUSHION(RC)	Remote Control Unit	2
318	501 1527 137	CARTON CASE		1

● Part indicated with the mark " ● " are not always in stock and possibly to take a long period of time for supplying, or in some case supplying of part may be refused.

5

6

7

8

WARNING:

Parts marked with this symbol  have critical characteristics. Use ONLY replacement parts recommended by the manufacturer.

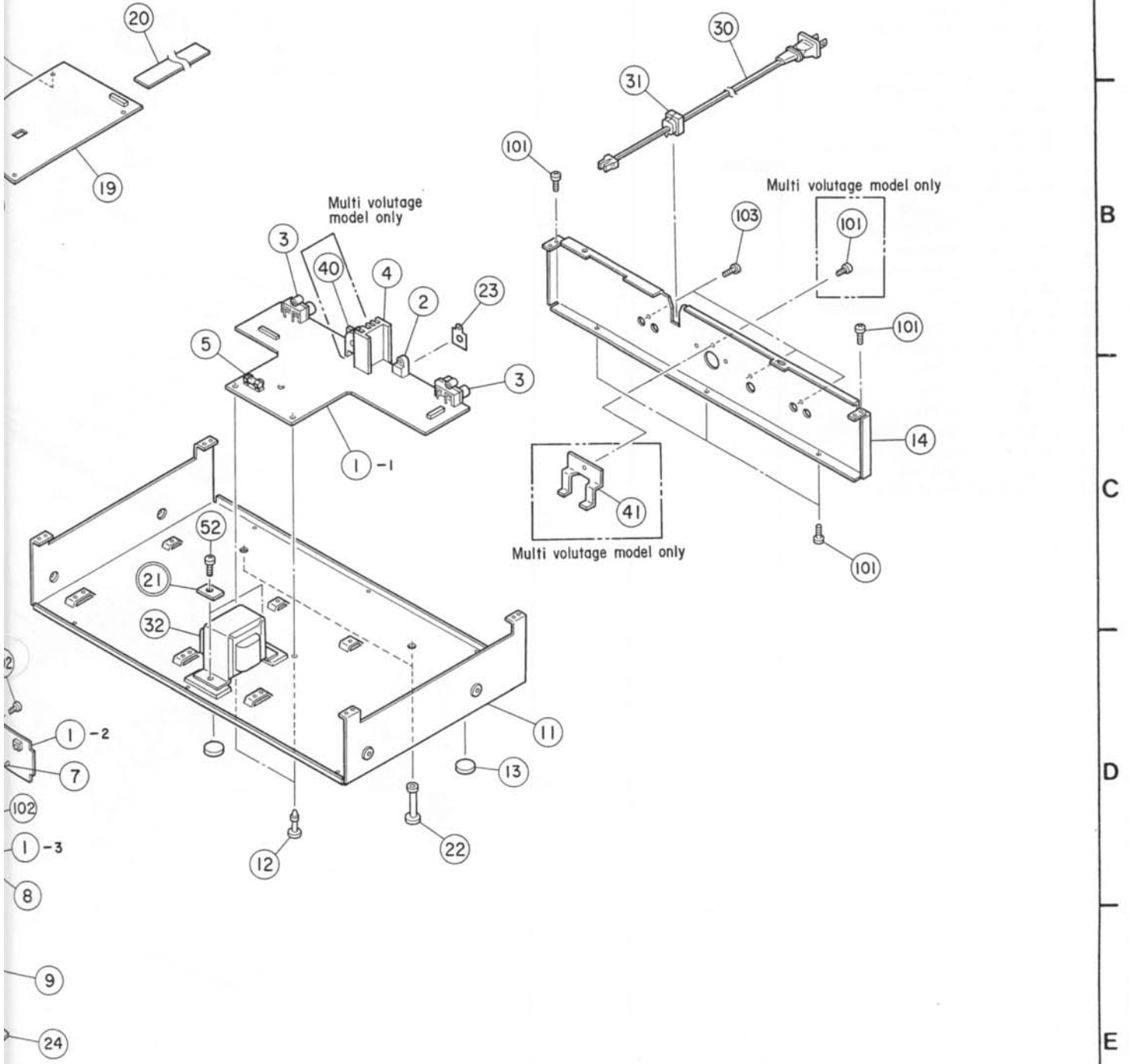

EXPLODED VIEW OF CHASSIS AND CABINET

1

2

3

4

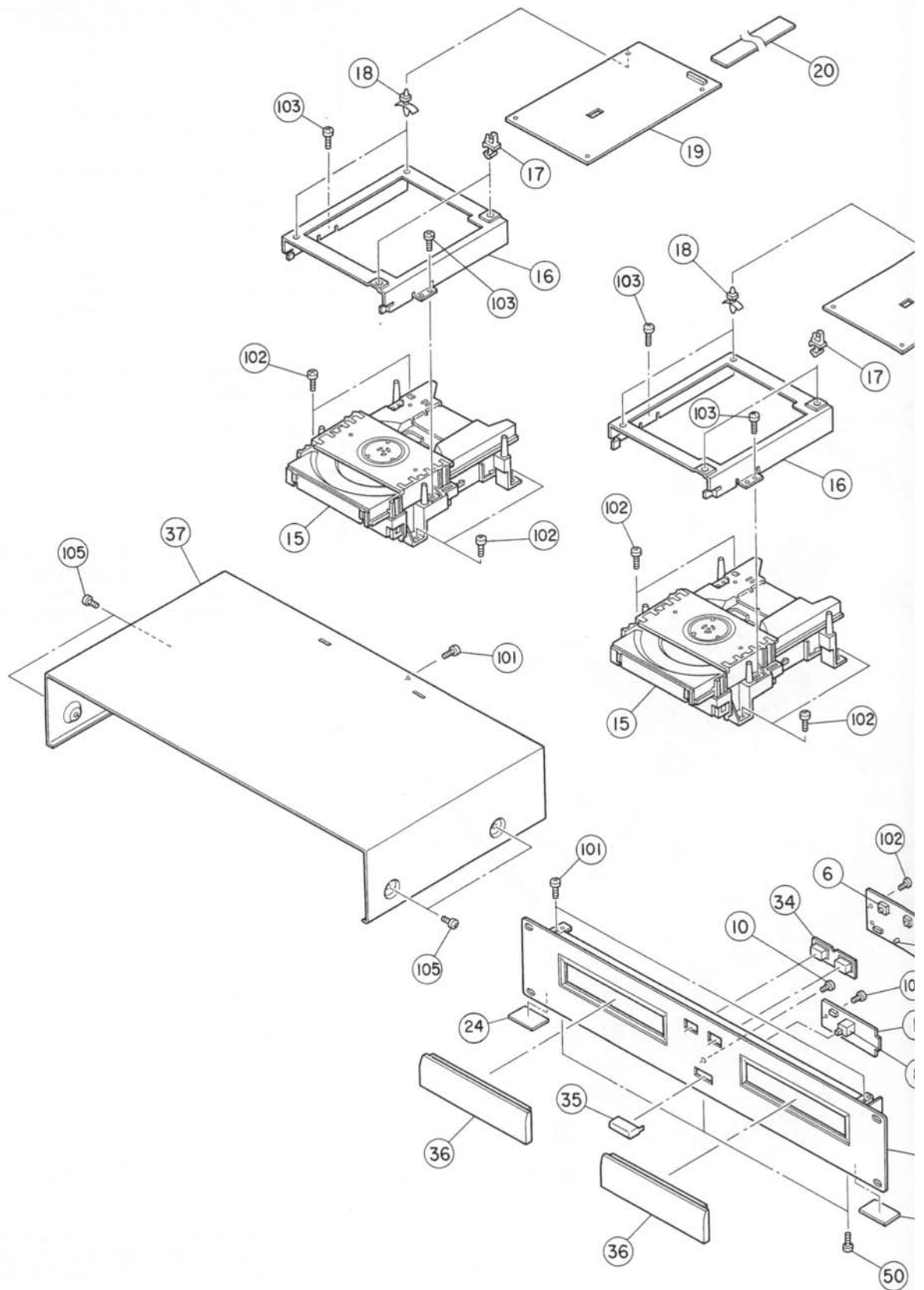

PARTS LIST OF FG-50 MECHA UNIT

PARTS LIST OF FG-50 MECHANISM UNIT

Ref. No.	Part No.	Part Name	Remarks
1	GEN 1396	Clamper Press Sub Ass'y	
3	412 3133 006	Clamper Frame	
5	431 0300 302	Loader Frame	
6	463 0669 008	Lock Lever Spring	
7	412 3215 202	Lock Lever	
8	424 0162 005	Gear	
9	424 0160 104	Lift Cam	
10	477 0262 006	Special Screw	
11	212 1059 006	Open/Close SW.	
12	423 0056 011	Belt	
13	424 0161 103	Pulley Gear	
14	411 1019 300	Mecha. Chassis	
15	GEN 1492	L. Motor Sub Ass'y	
16	222 2275 006	Motor SW. P.W.B.	
17	203 8302 008	5-3, 2P PH-SAN CORD-R	
18	499 0191 009	Laser P.U	KSS-240A
19	443 1094 005	P.U. Shaft	
20	471 3801 039	2x3 CBS-Z	
21	GEN 1636	Spindle Motor Ass'y	
22	424 0164 003	Helical Gear	
23	GEN 1397	Slide Motor Sub Ass'y	
24	462 0078 104	Damper	
25	203 8301 009	5-3, 2P PH-SAN CORD-W	
26	443 1093 006	FFC Clamper	
27	212 6013 005	Inner SW. (PU)	
28	009 0051 001	12P FFC	
29	462 0078 117	Damper	
30	463 0583 100	Spring (F)	
31	GEN 1408	Mecha. Frame Sub Ass'y	
32	461 0661 000	Spring F. (R)	
33	435 0117 403	Slide Rack	
34	462 0113 014	Rubber Washer	

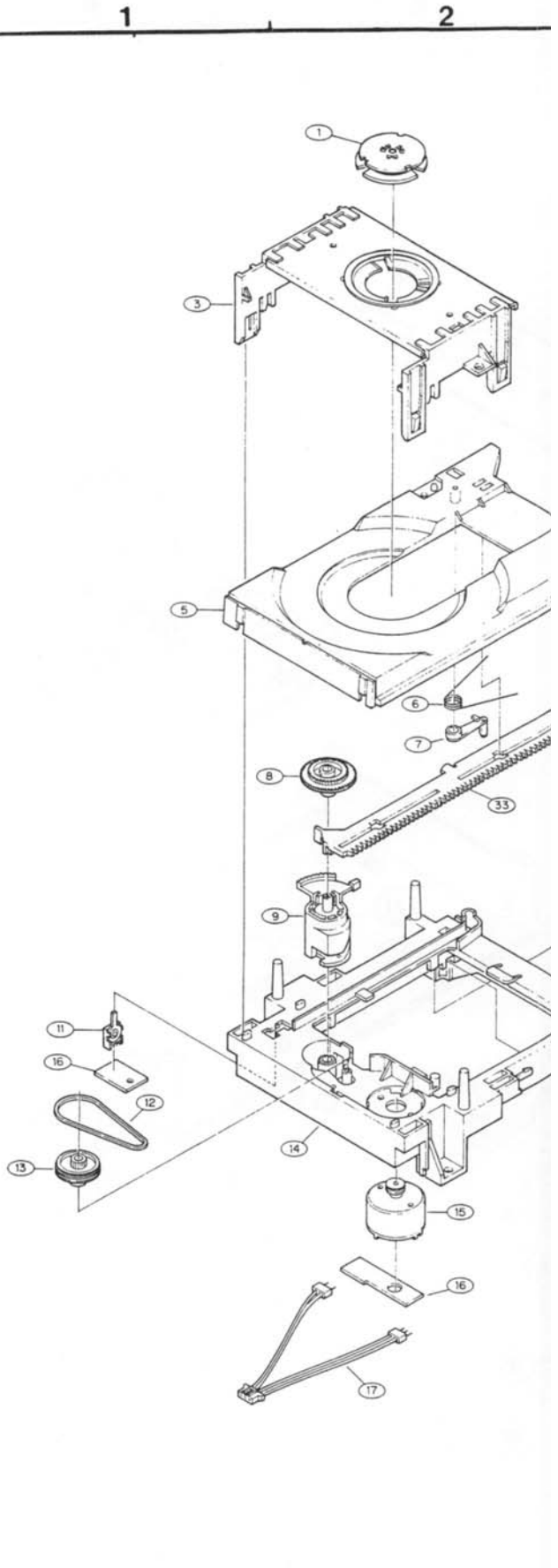

3

4

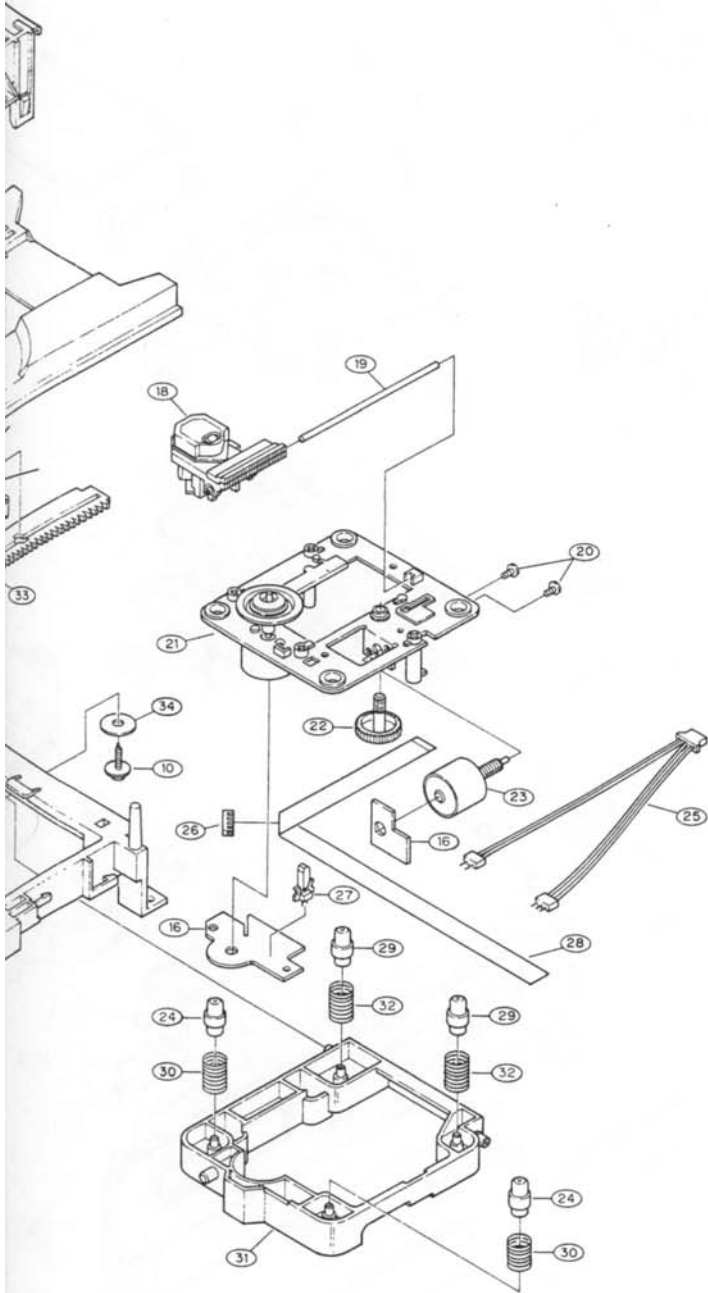

PART LIST OF RC-35 CONTROL UNIT

Ref. No.	Part No.	Part Name	Remarks	Q'ty
① 1	GU- 2403	CONTROL PWB UNIT		1
1-1	GU- 2403 -1	CPU PWB UNIT		
1-2	GU- 2403 -2	LEFT PWB UNIT		
1-3	GU- 2403 -3	RIGHT PWB UNIT		
2	393 9511 104	LED BACK LIGHT		1
3	393 4139 002	LCD		2
4	211 0763 015	SLIDE VOLUME		2
5	212 4763 904	TACT SWITCH(LONG ST)		24
6	393 9462 017	LED (RED)	SLR-40VC3F	2
7	393 9512 006	LED (GRN)	SLR-40MC	4
8	205 0717 008	8P MINI DIN CONN.BASE		1
9	—			
① 10	144 2191 107	RC FRONT PANEL ASS'Y		1
① 11	146 1371 005	LED WINDOW		6
① 12	449 0074 011	LOCKING CARD SPACER		2
① 13	146 1369 101	INNER PANEL		2
14	—			
15	119 0068 100	RUBBER BUTTON (A)		2
16	119 0069 109	RUBBER BUTTON (B)		1
① 17	105 1030 109	COVER		1
① 18	146 1370 200	WINDOW		2
19	113 1523 002	SLIDE KNOB		2
① 20	461 0653 005	CUSHION (M)		1
① 21	461 0504 002	PAD		1
① 22	412 3555 108	EARTH PLATE		1
101	473 7015 005	TAPPING SCREW 3×6 (S)	Black	4
103	473 7508 017	TAPPING SCREW 3×10(P)	Black	1
105	473 7500 015	TAPPING SCREW 3×8 (P)		8
106	473 7002 021	TAPPING SCREW 3×8 (S)	Black	8

● Part indicated with the mark " ① " are not always in stock and possibly to take a long period of time for supplying, or in some case supplying of part may be refused.

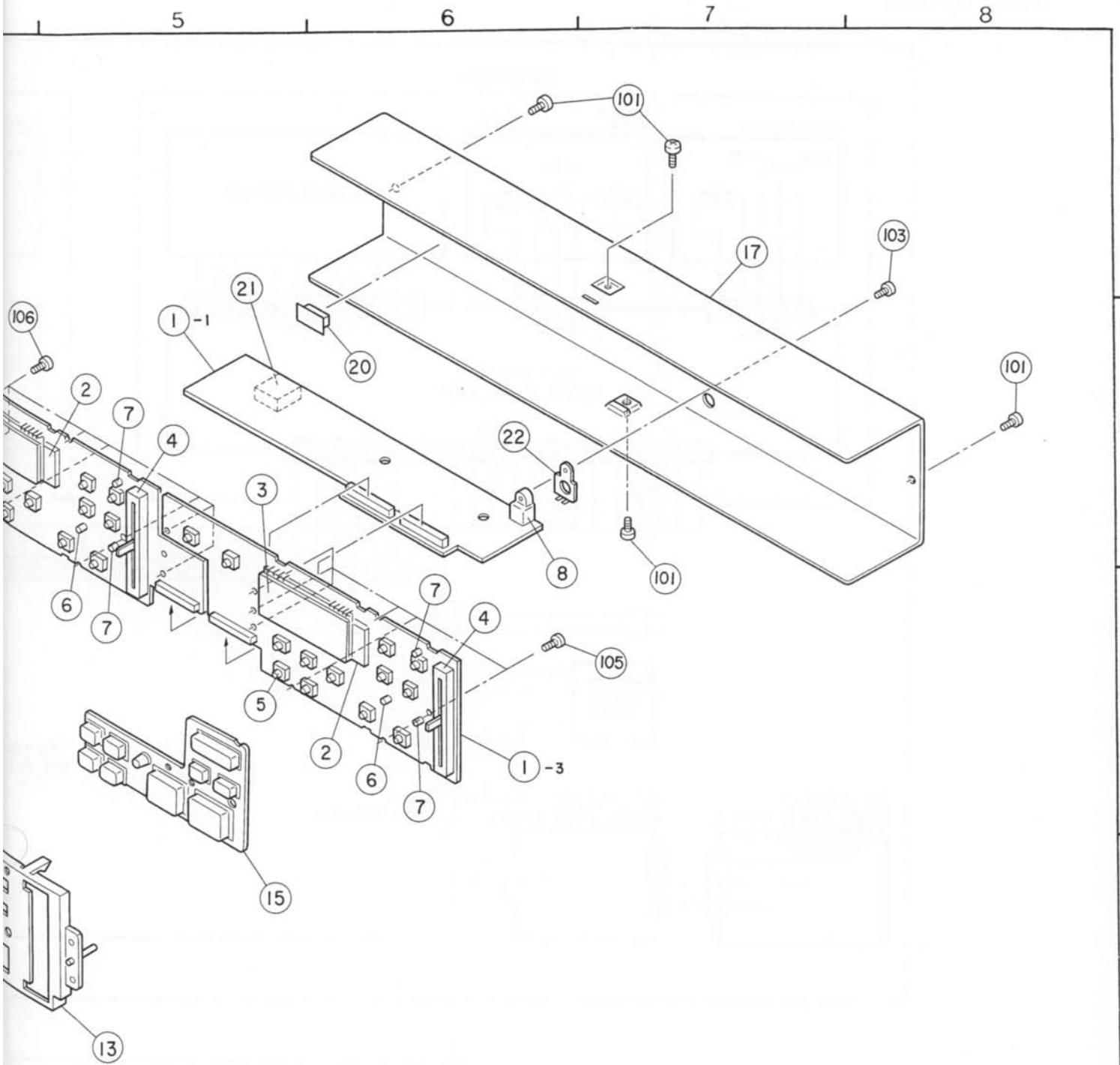

WARNING:
Parts marked with this symbol  have critical characteristics.
Use ONLY replacement parts recommended by the manufacturer.

EXPLODED VIEW OF RC-35 CONTROL UNIT

1

2

3

4

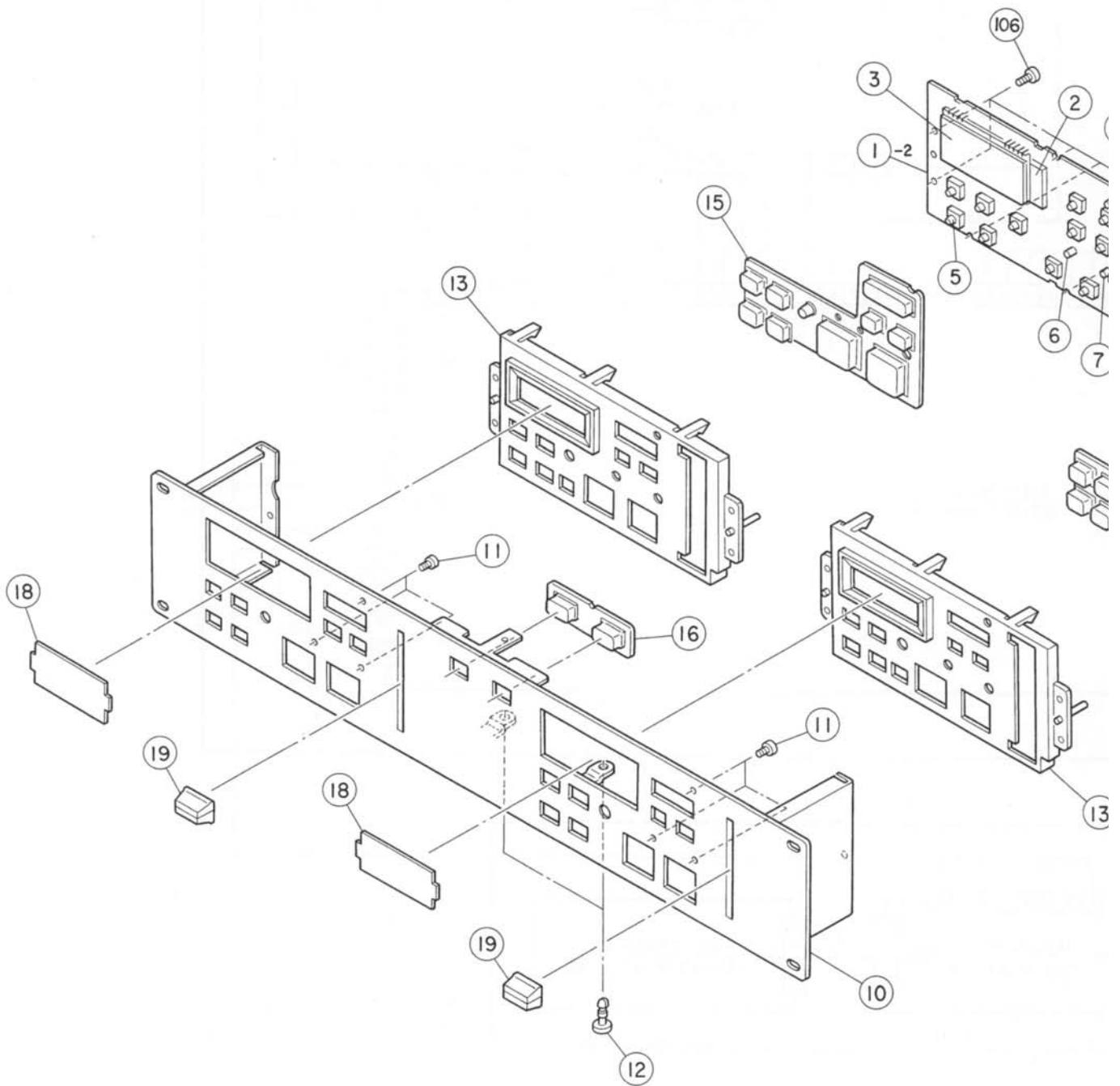

WIRING DIAGRAM

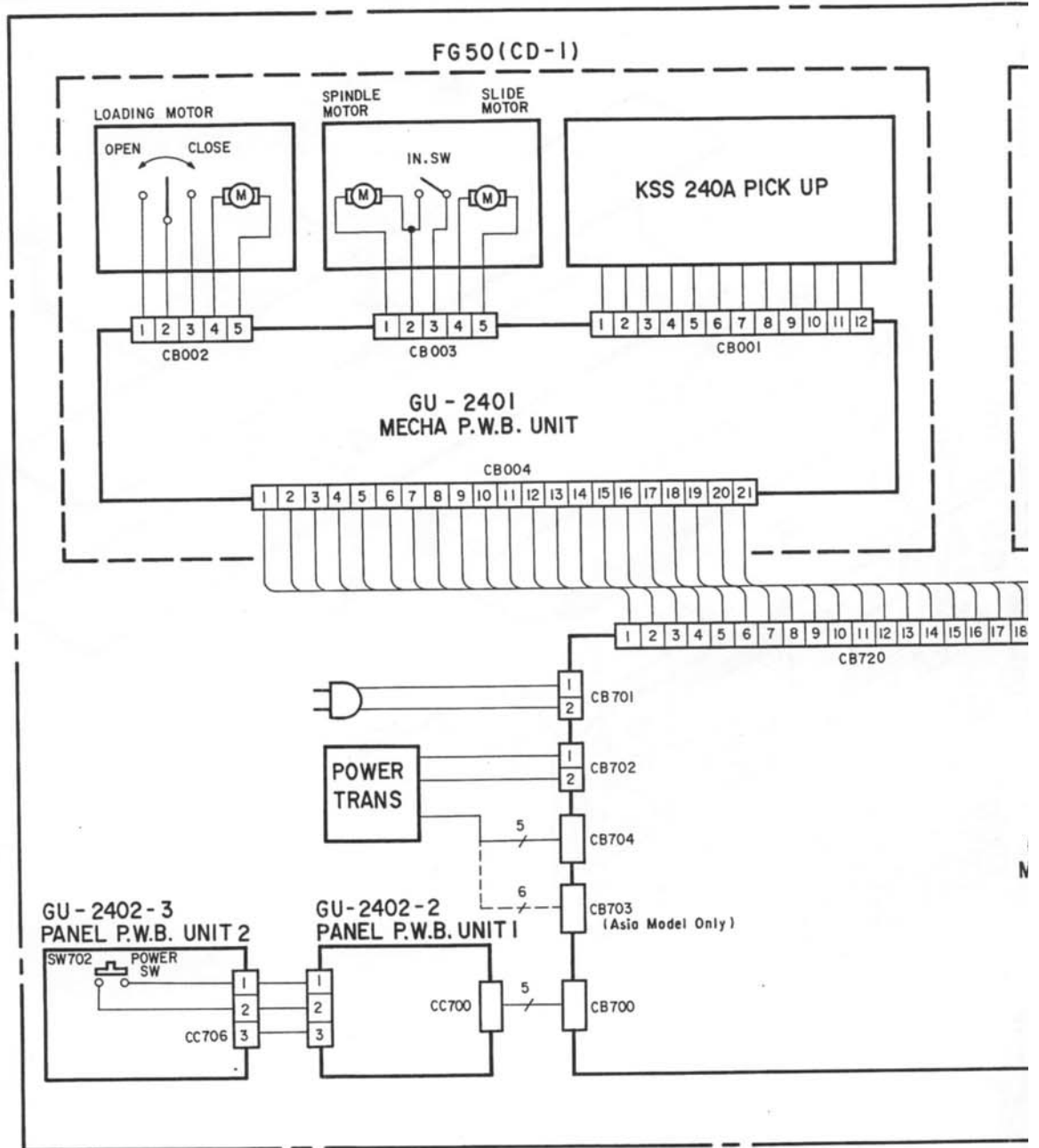

RC-35

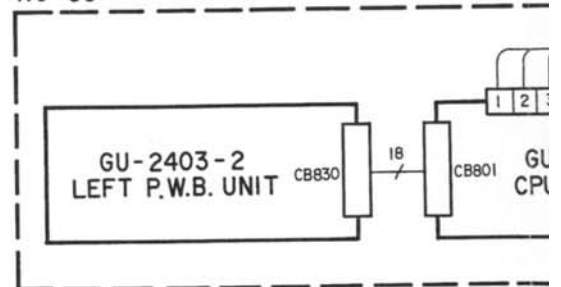

FG 50 (CD-2)

LOADING MOTOR

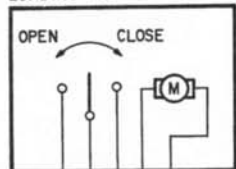

SPINDLE MOTOR

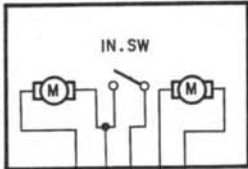

SLIDE MOTOR



KSS 240A PICK UP

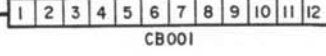

GU - 2401
MECHA P.W.B. UNIT

CB004

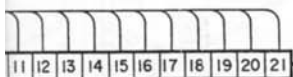
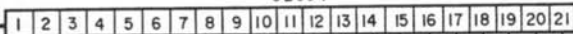

B720

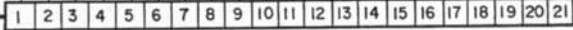

CB710

GU - 2402 - 1
MAIN P.W.B. UNIT



CB721

CB705

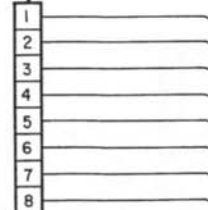

CB711



GU - 2403 - 1
CPU P.W.B. UNIT

GU - 2403 - 3
RIGHT P.W.B. UNIT

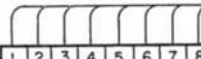

CB801

CB800

CB810

18

18

SCHMATIC DIAGRAM GU-2401 MECHA P.W.B. UNIT/GU-2402 MAIN P.W.B. UNIT

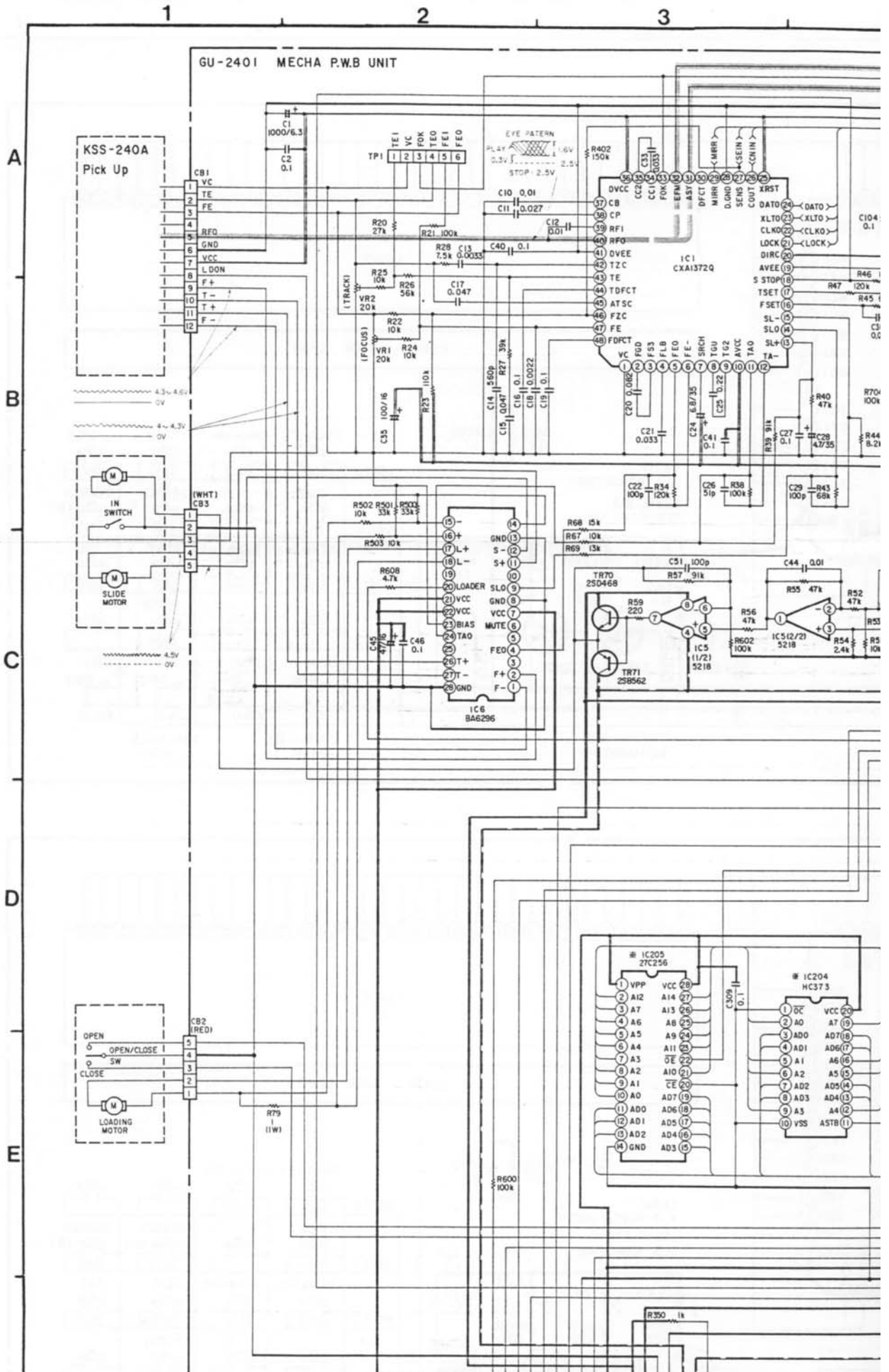

4

5

6

7

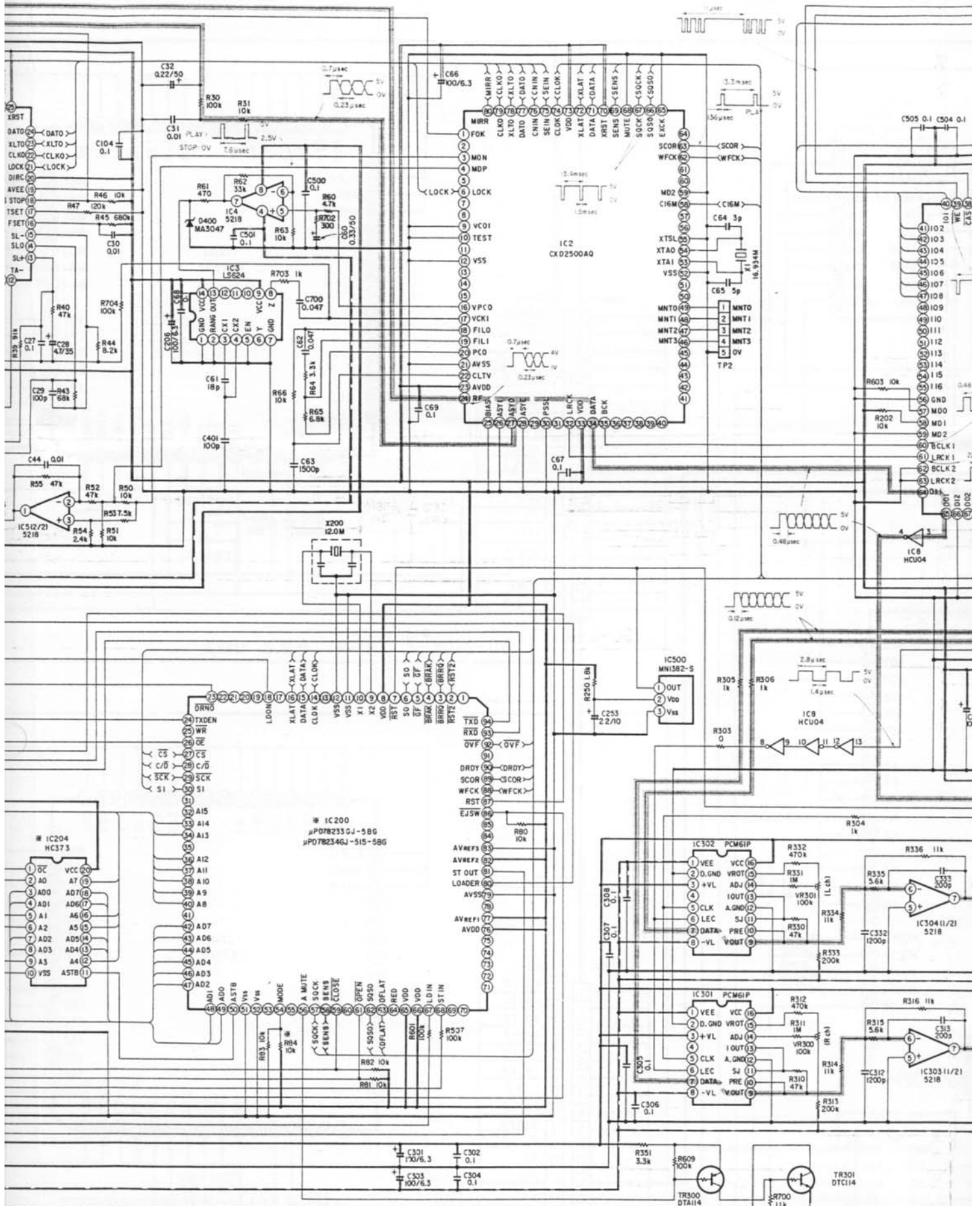

C
D
E
F
G
H

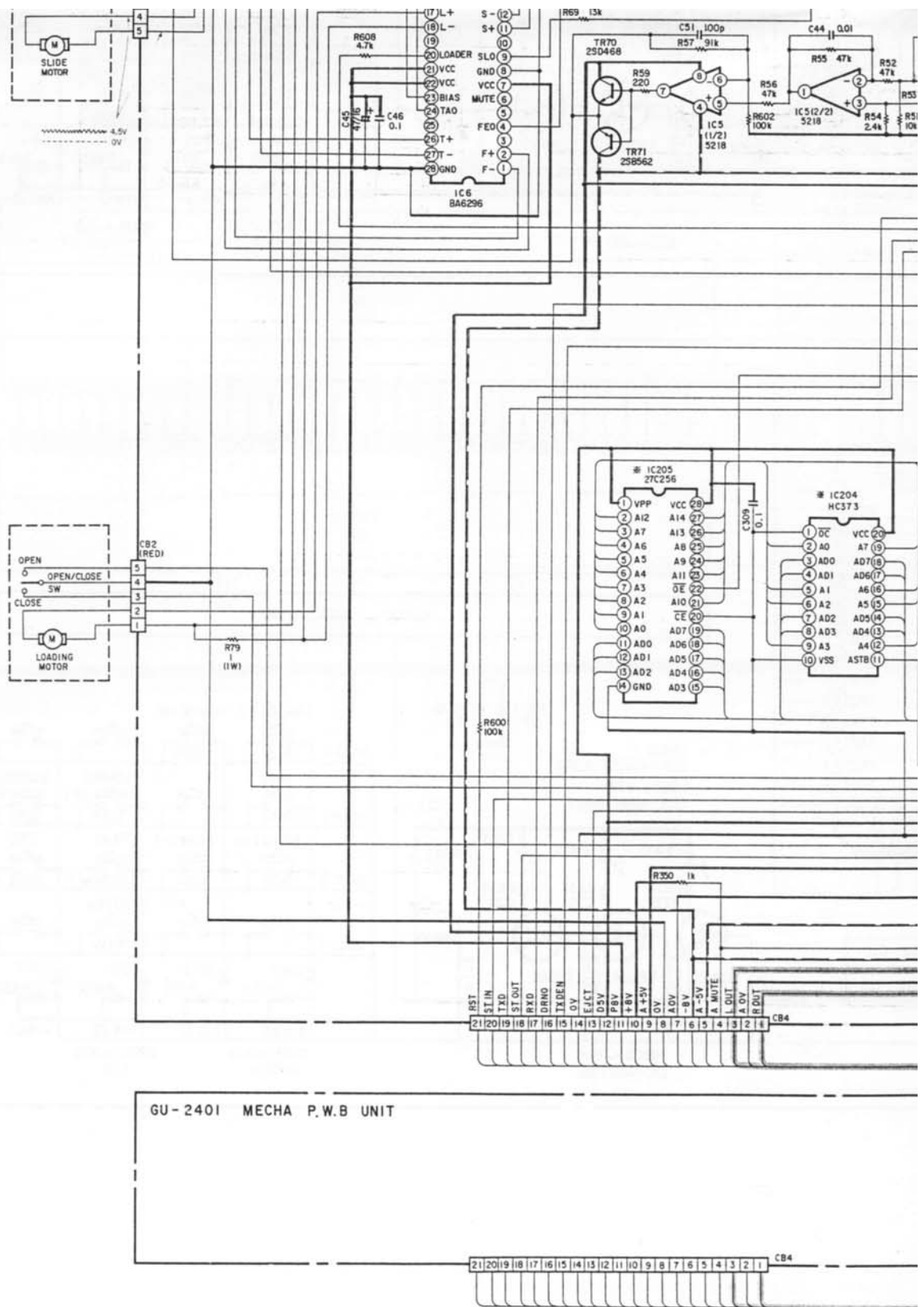

NOTES
 ALL RESISTANCE VALUES IN OHM. k=1,000 OHM, M=1,000,000 OHM
 ALL CAPACITANCE VALUES IN MICRO FARAD. P=MICRO-MICRO FARAD
 EACH VOLTAGE AND CURRENT ARE MEASURED AT NO SIGNAL INPUT CONDITION.
 CIRCUIT AND PARTS ARE SUBJECT TO CHANGE WITHOUT PRIOR NOTICE.

WARNING:
 Parts marked with
 Use ONLY replac

CAUTION:
 Before returning t
 the leakage curre
 defective.

WARNING:
 DO NOT return th

NOTES:
 Circuit and parts :

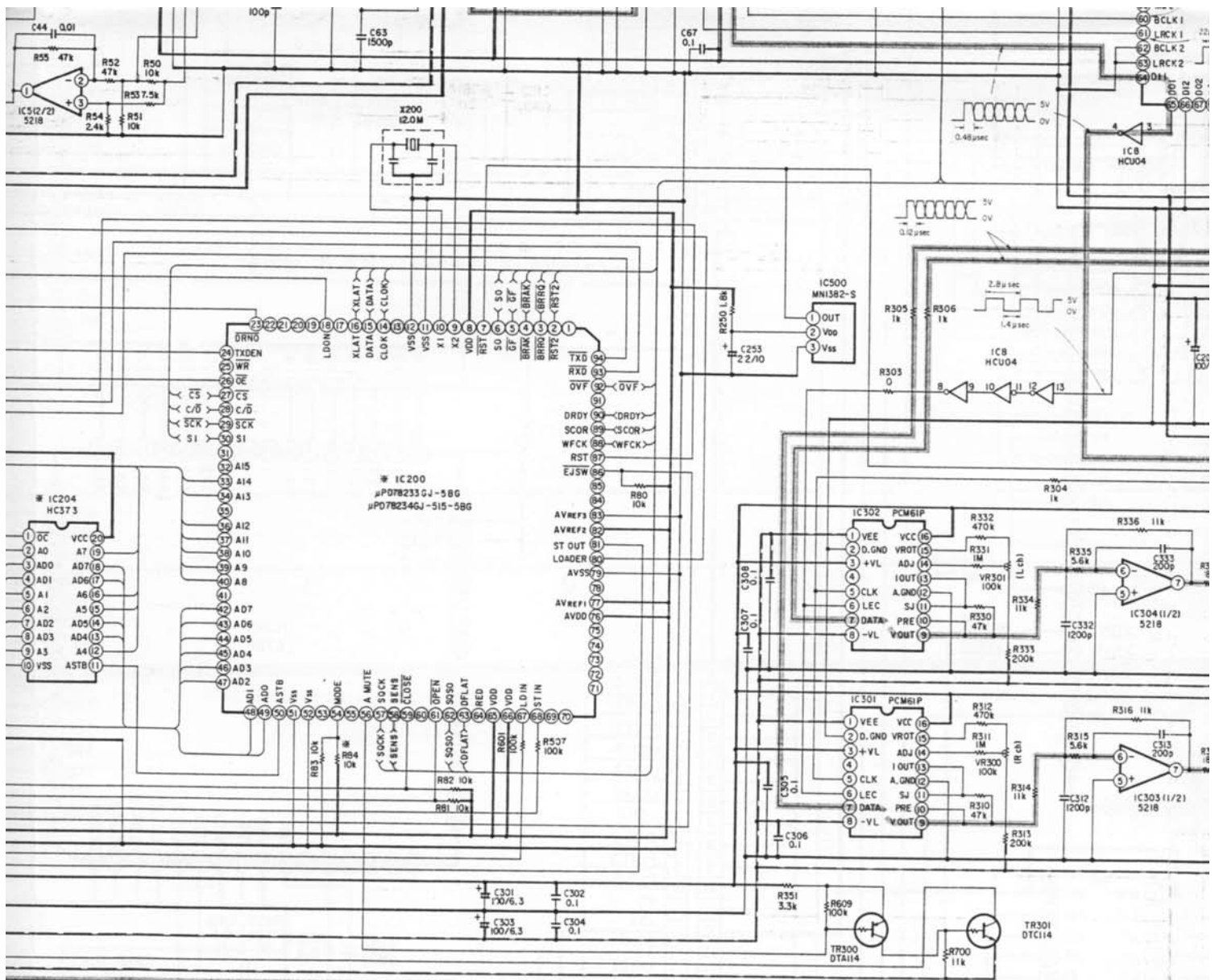

(SAME AS ABOVE)

WARNING:

Parts marked with this symbol have critical characteristics. Use ONLY replacement parts recommended by the manufacturer.

CAUTION:

Before returning the unit to the customer, make sure you make either (1) a leakage current check or (2) a line to chassis resistance check. If the leakage current exceeds 0.5 milliamperes, or if the resistance from chassis to either side of the power cord is less than 240 kohms, the unit is defective.

WARNING:

DO NOT return the unit to the customer until the problem is located and corrected.

NOTES:

Circuit and parts are subject to change without prior notice.

* For serial numbers 0 No. 301, of Canada M CPU masking and m

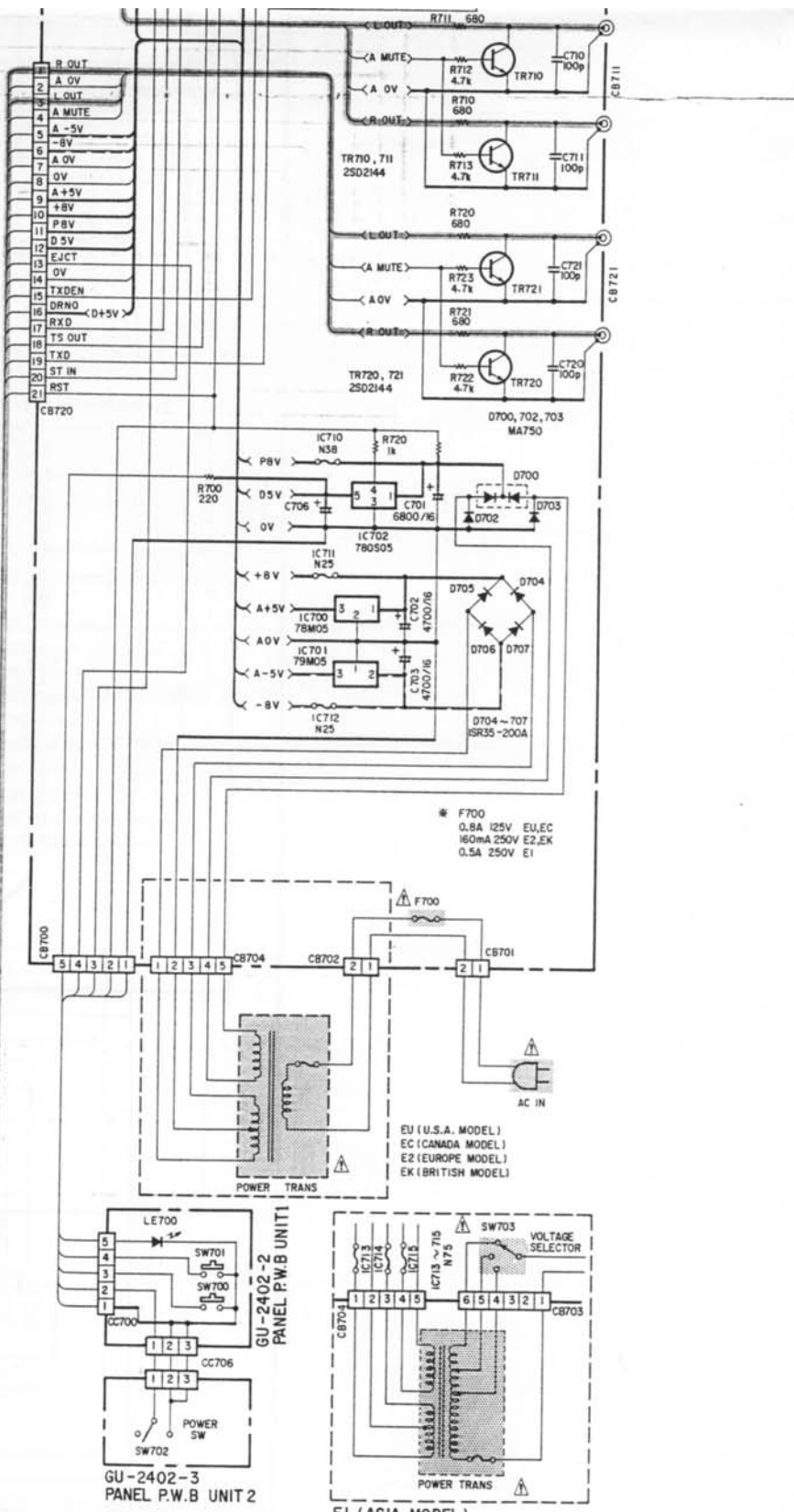
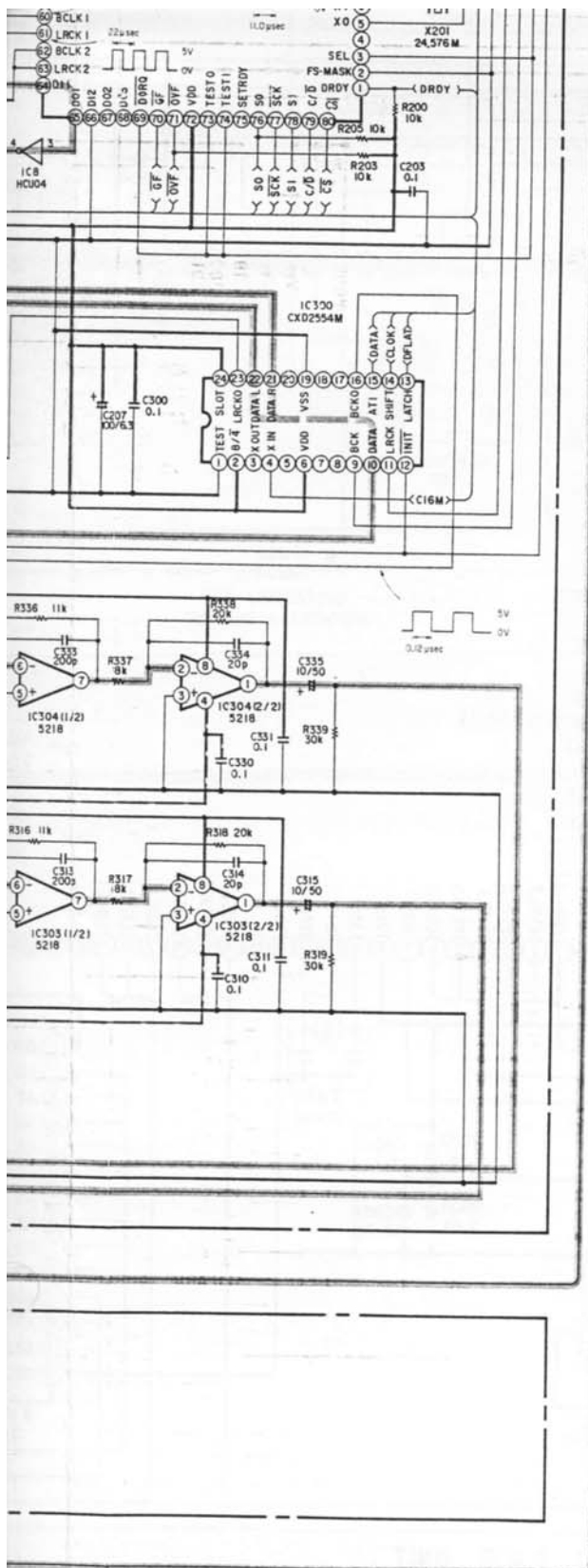

————— +B LINE
 - - - - - - - - - -B LINE
 [Dotted Line] SIGNAL LINE

Serial numbers of U.S.A. Model after No. 621, of Europe Model up to No.882-885 and after No.951, of U.K. Model after No. 101, of Canada Model after No. 131, and of Multi-Voltage Model after No. 101, IC200 becomes UPD78234 GJ-515-5BG by reworking and makes IC204, IC205, R84 unnecessary.

SCHEMATIC DIAGRAM GU-2403 CONTROL P.W.B. UNIT

1

2

3

4

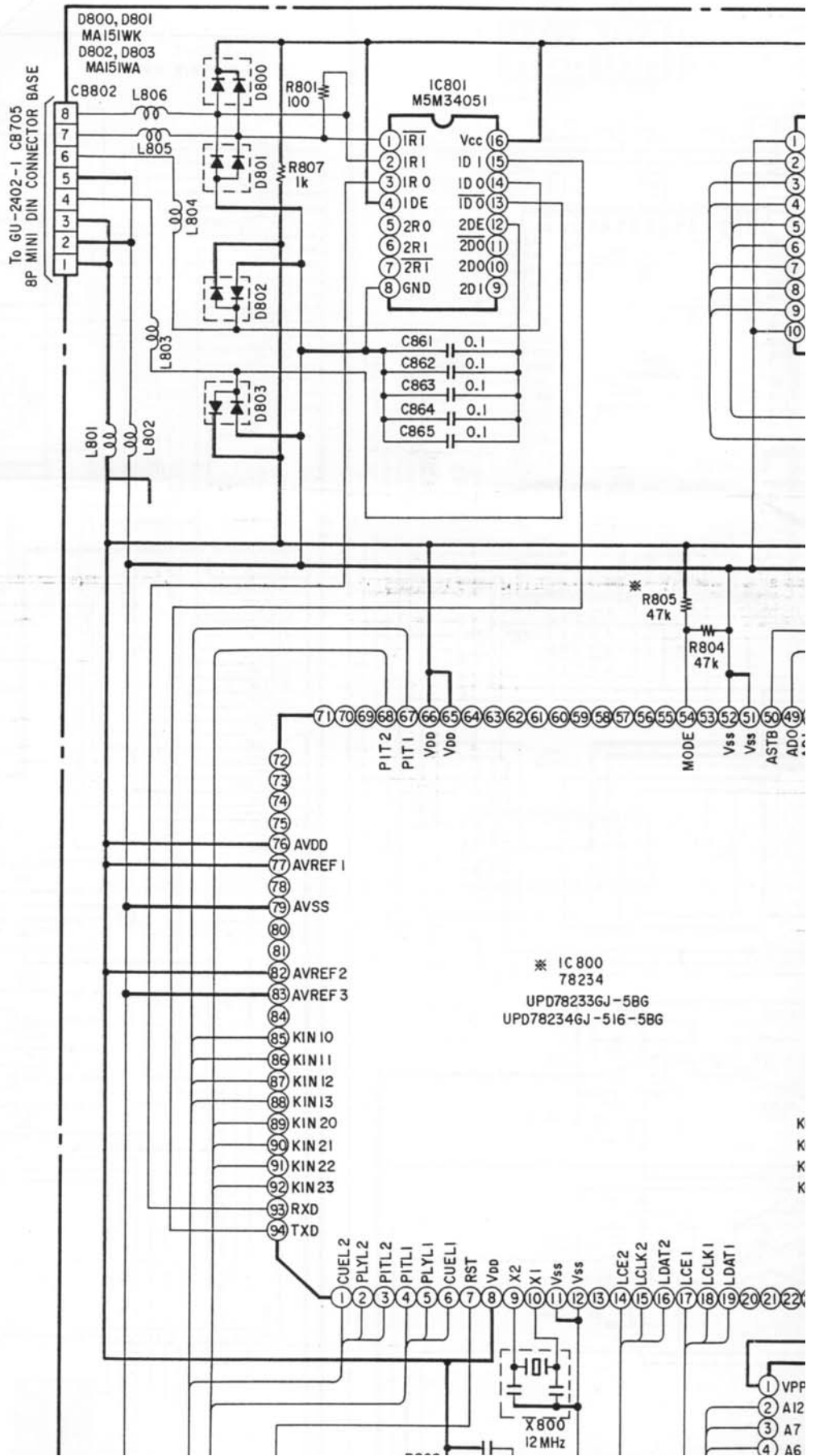

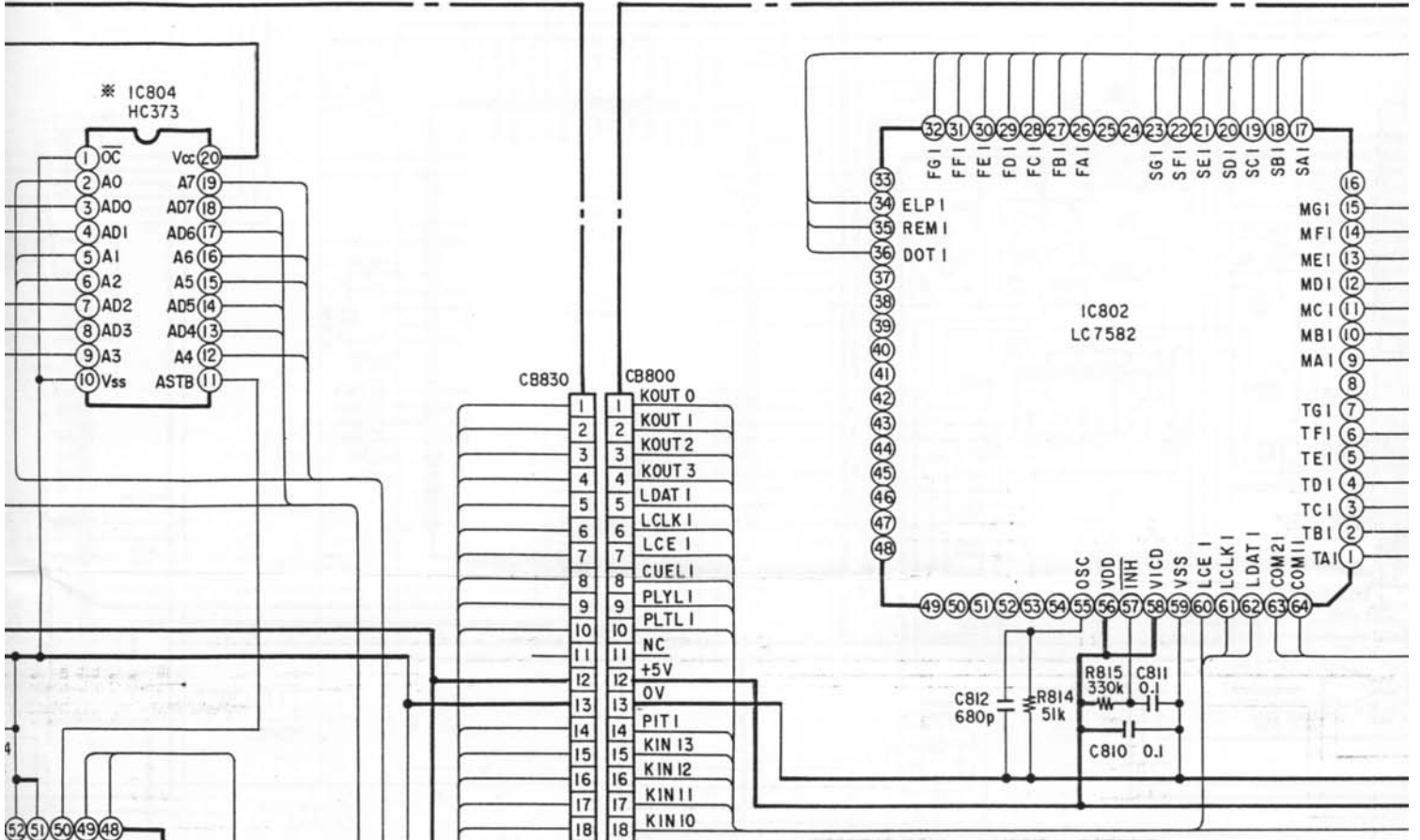

GU-2403-2 RIGHT P.W.B UNIT

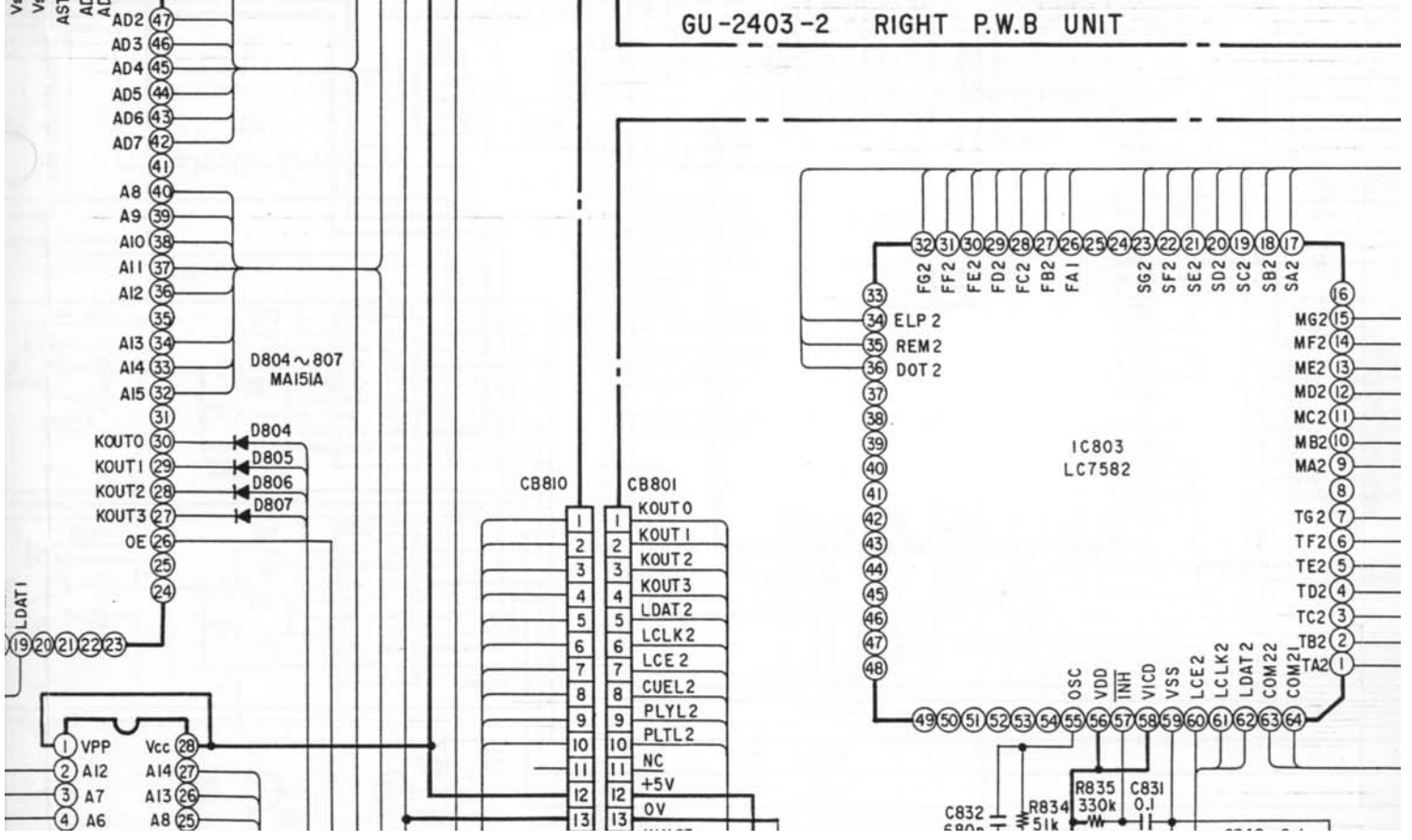

8

9

10

11

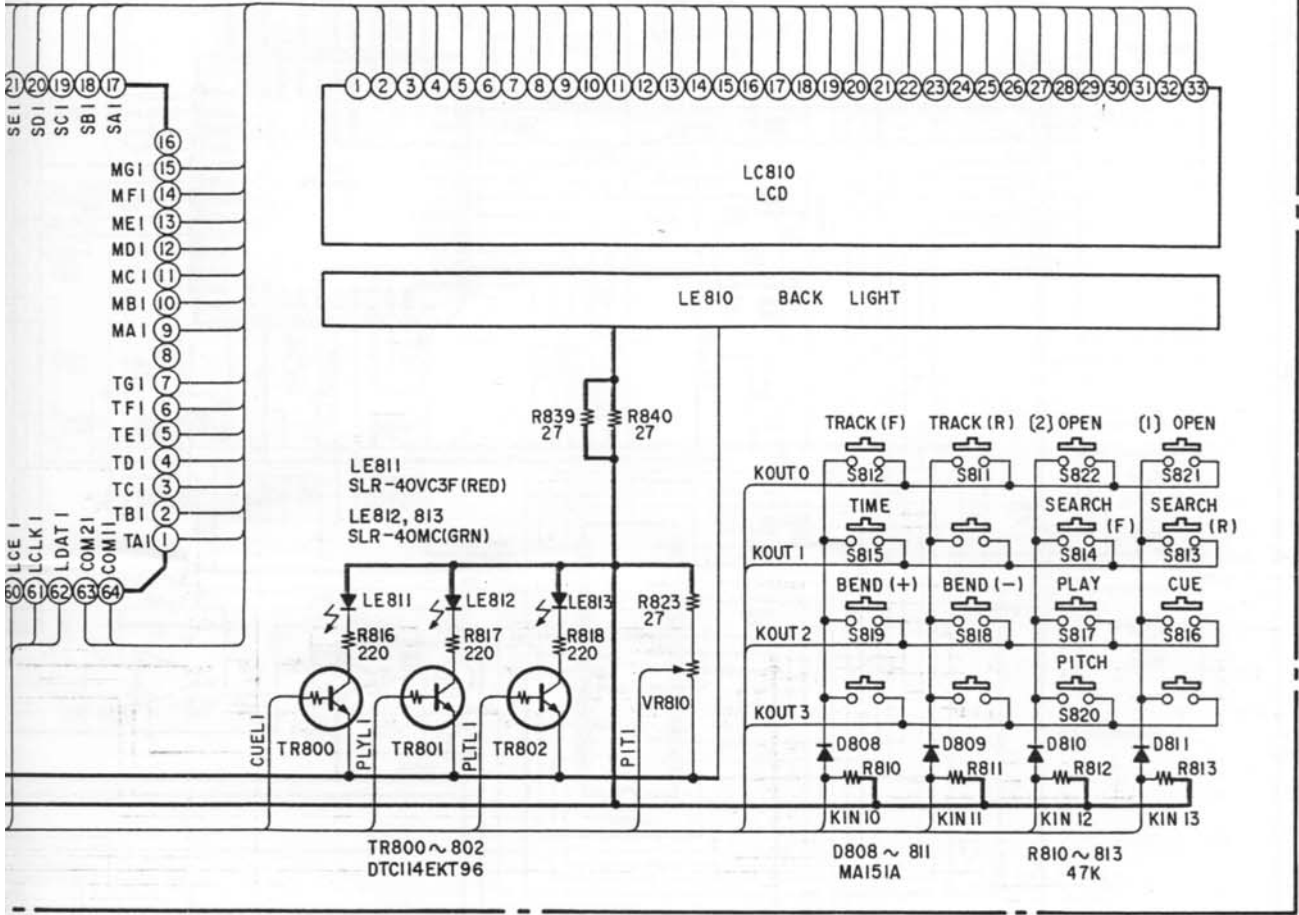

A

B

C

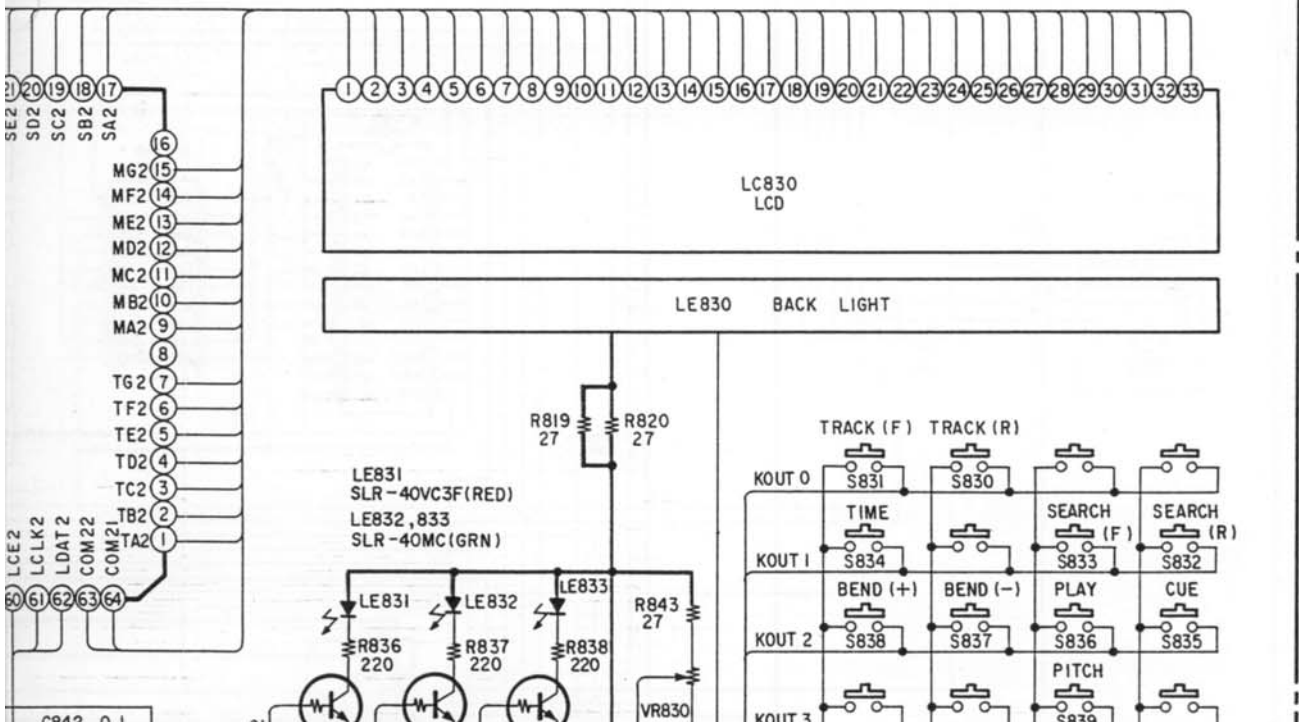

D

E

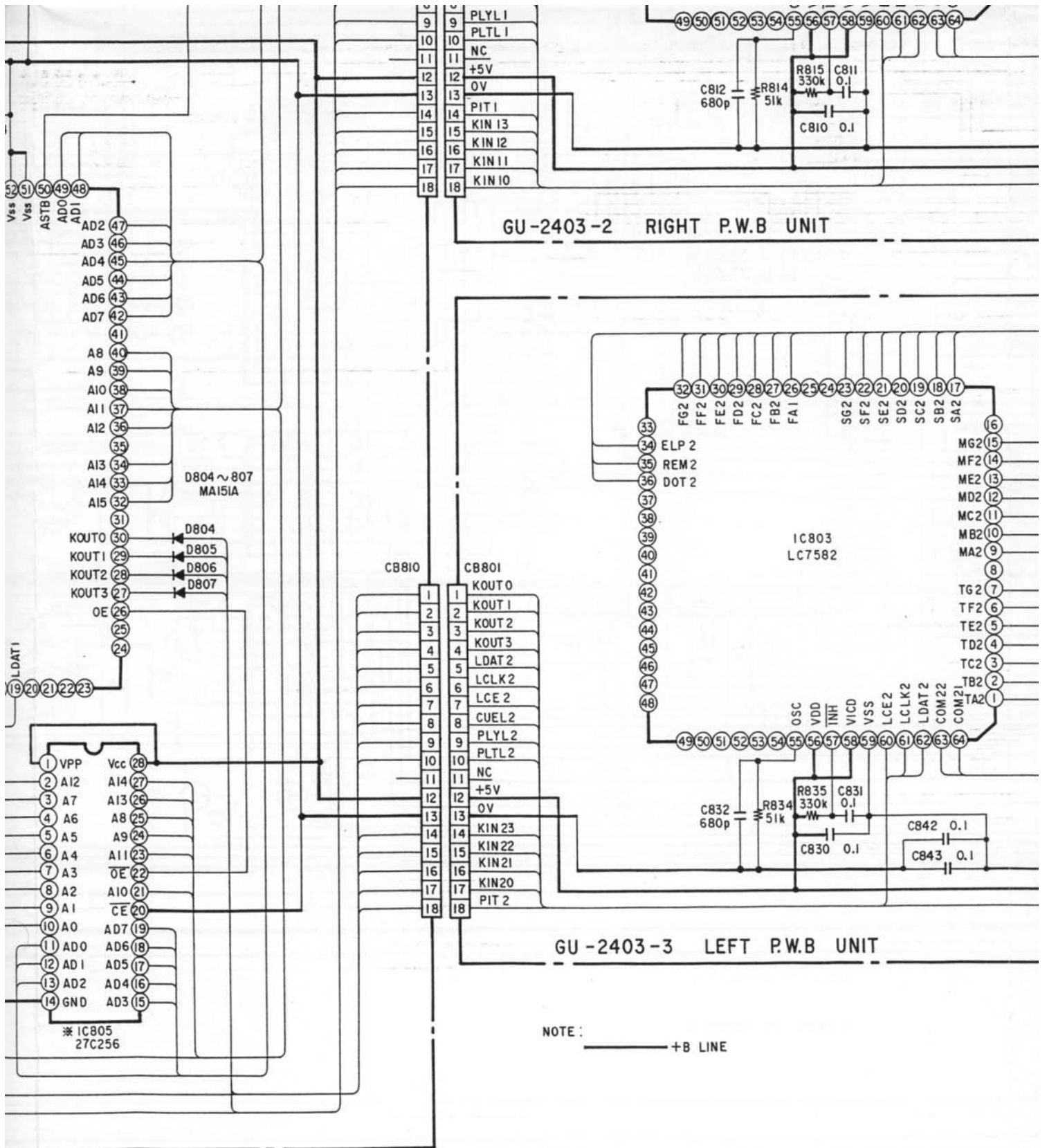

882-885 and after No.951, of U.K. Model after No.101, IC800 becomes UPD78234 GJ-516-5BG by

NOTES

ALL RESISTANCE VALUES IN OHM. K=1,000 OHM, M=1,000,000 OHM
 ALL CAPACITANCE VALUES IN MICRO FARAD. P=MICRO-MICRO FARAD
 EACH VOLTAGE AND CURRENT ARE MEASURED AT NO SIGNAL INPUT CONDITION.
 CIRCUIT AND PARTS ARE SUBJECT TO CHANGE WITHOUT PRIOR NOTICE.

WARNING:
 Parts marked with this symbol are not to be used in the repair of this equipment. Use ONLY re

CAUTION:
 Before returning this equipment to service, check for leakage of fluid or other defects.

WARNING:
 DO NOT return this equipment to service until it has been repaired by a qualified technician.

NOTES:
 Circuit and parts are subject to change without prior notice.

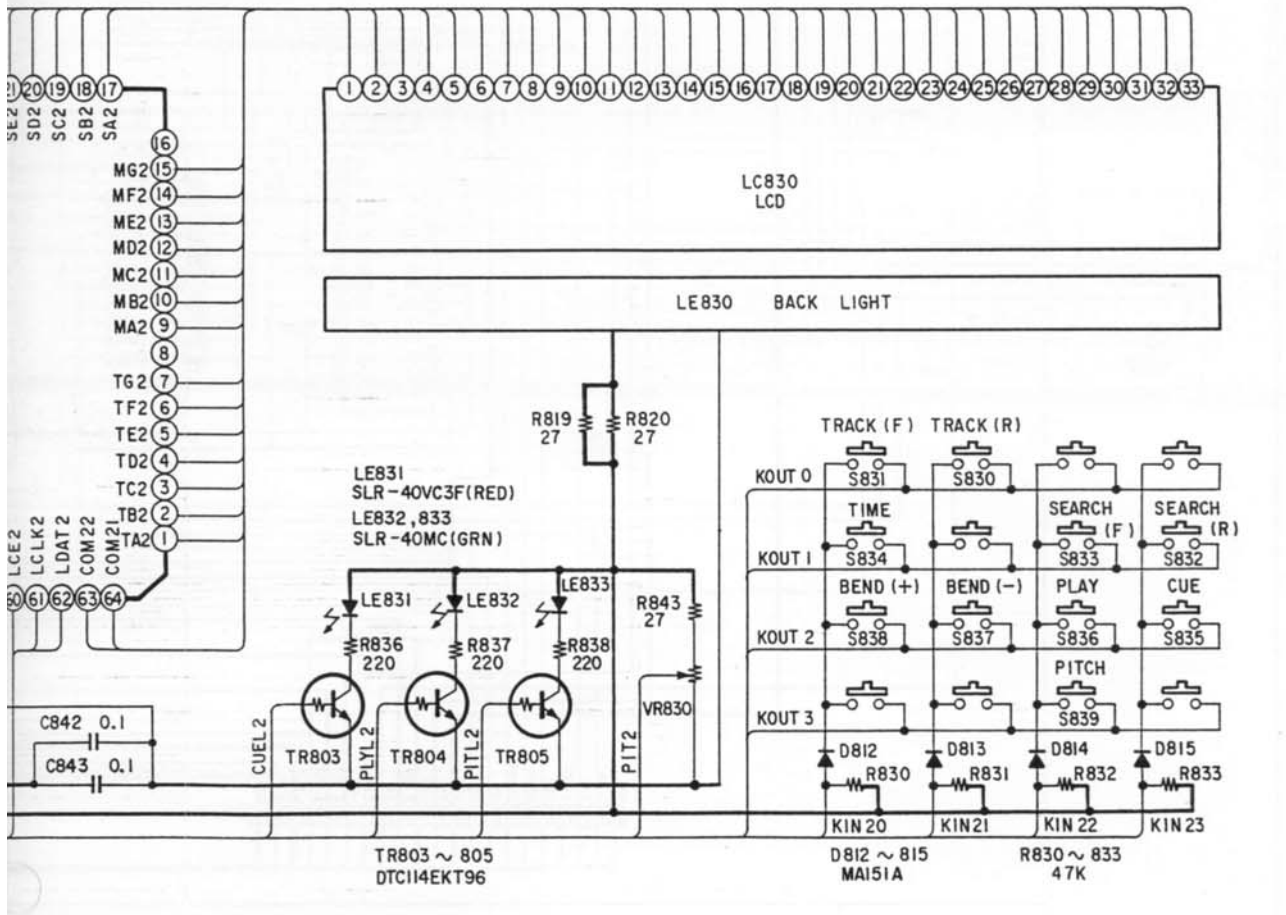
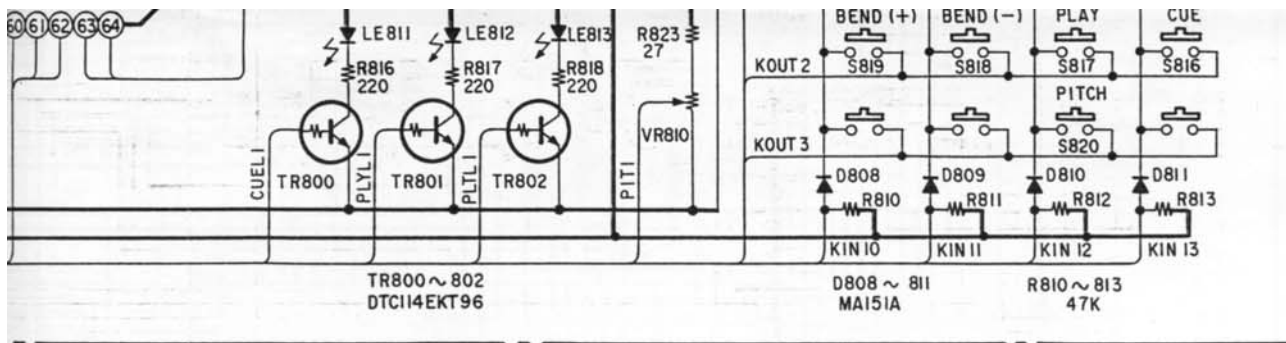

WARNING:
Parts marked with this symbol Δ have critical characteristics.
Use ONLY replacement parts recommended by the manufacturer.

CAUTION:
Before returning the unit to the customer, make sure you make either (1) a leakage current check or (2) a line to chassis resistance check. If the leakage current exceeds 0.5 millamps, or if the resistance from chassis to either side of the power cord is less than 240 kohms, the unit is defective.

WARNING:
DO NOT return the unit to the customer until the problem is located and corrected.

NOTES:
Circuit and parts are subject to change without prior notice.

C
D
E
F
G
H

UPD78233GJ-5BG (IC200,800)

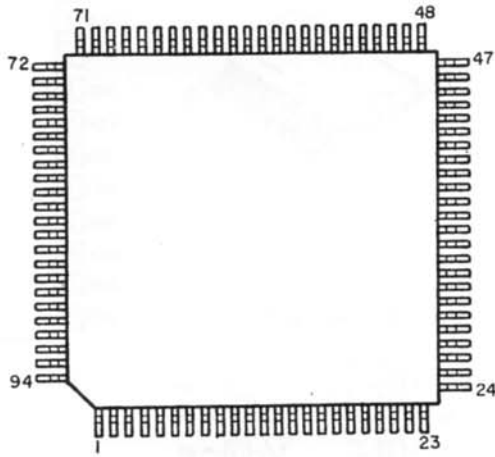

HD74HC373FP-TL (IC204,804)

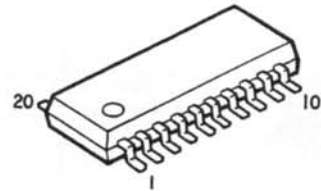

M5M34051FP (IC801)

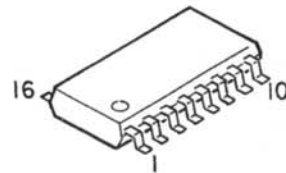

PCM61P-L (IC301,302)
M5M34051P (IC703)

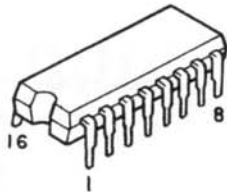

BA6296 FP-T1 (IC006)

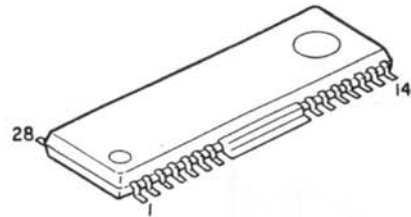

L780S05 (IC702)

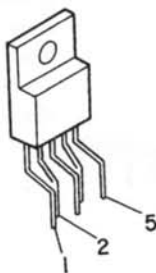

- 1. Vin
- 2. NC
- 3. GND
- 4. STB
- 5. Vout

NJM78M05FA (IC700)
NJM79M05FA (IC701)

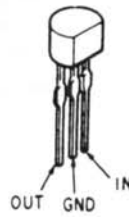

IC PROTECTOR
ICP-N38T (IC710)
ICP-N25T (IC711,712)



Segment

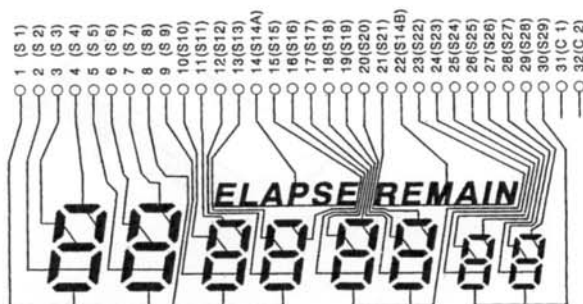

Common

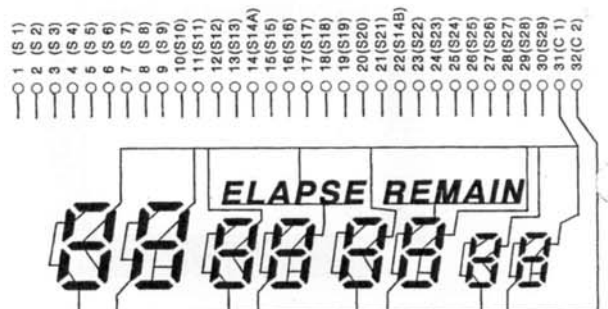

● TRANSISTORS

2SB562(C) (TR073)
2SD468(C) (TR072)

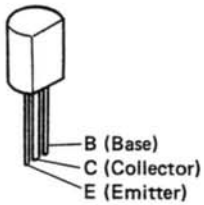

DTC114EK96
(TR300,301)
(TR800-805)

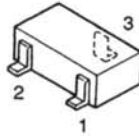

1: GND/Emitter
2: In/Base
3: Out/Collector

2SD2144STPU
(TR710, 720
720,721)

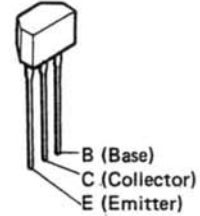

● DIODES

MA151A (D804 - 815)
MA151WA (D802,803)

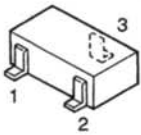

1: Anode
2: Cathode
3: Anode / Cathode

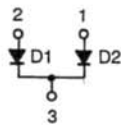

MA151WK
(D800,801)

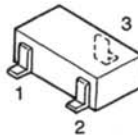

1: Anode
2: Cathode
3: Anode / Cathode

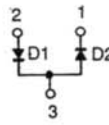

MA3047-TX (D400)

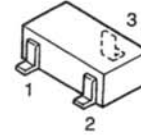

1: Anode
2: NC
3: Cathode

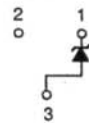

1SR35-200A (D704-707)

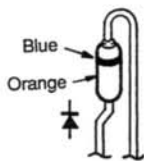

1SS270A TE (D708- 715)



MA750 (D700,702,703)

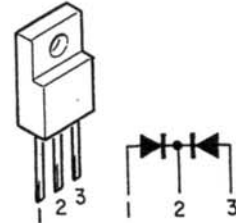

● LED

BACK LIGHT (LE810,830)

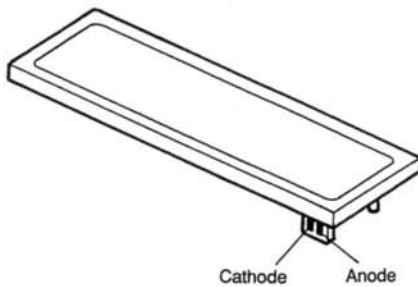

SLR-40VC3F (RED) (LE811,831)
SLR-40MC3F (GRN) (LE812,813,832,833)

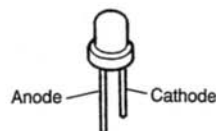

DENON

NIPPON COLUMBIA CO. LTD.

14-14, 4-CHOME AKASAKA,
MINATO-KU, TOKYO 107-11 JAPAN
TEL: 03-3584-8111
TLX: JAPANOLA J22591
CABLE: NIPPONCOLUMBIA TOKYO

TRI-COMP